

Centrifugal pumps of plastic for clear or turbid fluids

Technical data

- Delivery rate
 $Q_{\max} = 60 \text{ l/min}$
- Delivery head
 $H_{\max} = 32 \text{ m}$
- Temperature range
 $-20 \text{ °C to } +60 \text{ °C}$

Product features

- Centrifugal pump,
1- to 4-stage models
- Closed impellers
- Connecting dimensions
to DIN EN 12157
- Immersion depths
of up to 320 mm
- Operation on 50 Hz and 60 Hz
without impeller change
- Three-phase or single-phase motor



Main applications

- Filling installations
- Wetting facilities
- Phototechnical systems
- Freon, Frigen installations
- Beverage cooling systems
- Air conditioning
- Cooling systems
- Cleaning/degreasing installations
- etc.

Fluids delivered

- Aqueous emulsions (with synthetic/mineral oil)
also with chemical additives
- Drinking water
- Distilled water
- Deionized water
- Bases and acids
- Photo developer fluids
- etc.

Temperature range: $-20\text{ }^{\circ}\text{C}$ to $+60\text{ }^{\circ}\text{C}$.

Maximum grain size: 0.3 mm.

Please select models PRT or PRA (PPU plastic) with open impellers when very dirty liquids are involved.

Product advantages

- Good resistance to chemicals
found in a large number of liquids –
thanks to high-quality POM and PEI plastics.
- High efficiency –
resulting from closed impellers and optimized pump hydraulics.
- Space-saving installation –
because of low motor heights.
- Easy to handle –
due to low weights.

Design features

- sealless
- free-floating pump shaft,
supported only by motor bearings
- closed impellers
- 1- to 4 stage models
- installation and port dimensions to DIN EN 12157
- immersion depths of up to 320 mm

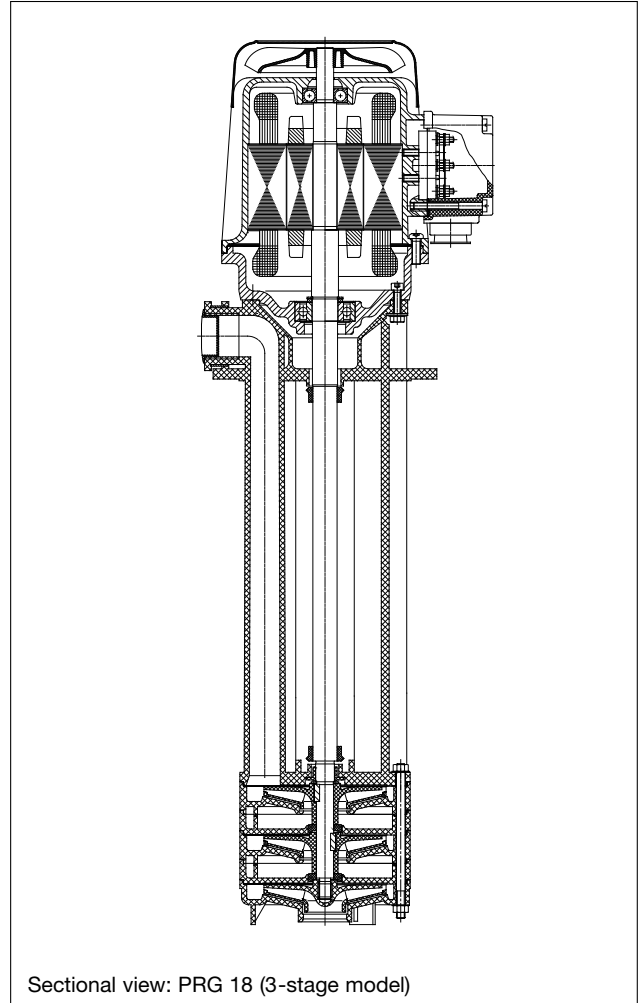

High-tech plastics POM and PEI

The acetal copolymer **POM** belongs to the polymer group. Thanks to its special chemical structure (base polymer of trioxane with small amounts of comonomers), POM is highly stable in respect to thermal and oxidative degradation.

As a result, this plastic provides the pump's parts with high fatigue strength and very good resistance to chemicals and aging.

The amorphous thermoplastic polyetherimide **PEI** displays outstanding thermal and mechanical properties.

We chose this material for the impeller in order to lengthen the pump's service life, especially when different degrees of water hardness and severe erosion are involved.

Both plastics, POM and PEI, are physiologically harmless and can be recycled. All the plastic pump parts are marked with the prescribed identification symbols.

Mechanical design

Component	Material
Motor housing	Aluminum
Pump support	POM/GF
Pump bottom	POM/GF
Intermediate chamber	POM/GF
Impeller	PEI/GF
Shaft	Stainless steel No. 1.4122
Antifriction bearings	Radial deep-groove ball bearings with 2 side plates (2 Z); with permanent lubrication
Self-adjusting bush	Teflon/graphite
Small parts (in contact with the fluid)	Stainless steel

Electrical design

The drive motors have a sophisticated fail-safe winding that is baked instead of impregnated. They meet VDE regulations as well as European motor standards (DIN EN 60034-1/11.95) and the requirements underlying the CE mark.

Designs in conformity with non-European regulations, e.g. Canadian Standards Association (CSA), Underwriters Laboratories INC. (UL) or special requirements, e.g. the USA or Japan, are possible. Moreover, we also produce models for special operating conditions (e.g. exposure to humidity or dust).

The regular models have motor windings designed for continuous operation and connection to a mains voltage of 230/400 V ±10%, 50 Hz in accordance with IEC 38/5.87.

On request the motors can be customized to all common mains values.

	Standard	Options
Degree of protection (DIN EN 60034-5/4.88)	IP 54	IP 55
Insulation class	F.B	F
Ambient temperature (DIN EN 60034-1/11.95)	max. 40 °C	50 °C and higher
Relative humidity (DIN 50015)	max. 92 %	95 % and higher
Site altitude (DIN EN 60034-1/11.95)	< 1000 m above sea level	on request
Electrical parameters	230/400 V, 50 Hz 255/440 V, 60 Hz	on request
Mains operation	three-phase-	single-phase AC
Number of poles	2 poles	4 poles
Terminal box		
- layout (DIN EN 12157)	layout 1	layout 2, 3 or 4
- material	high impact plastic	light metal
- cable entry (DIN EN 50262)	M16x1.5	M20x1.5
		Industrial plug-in connector
Protective surface coating	synthetic-resin lacquer color: RAL 9005 (black, matt)	Special finish on request
Special protection		Motor protection (thermistor in the winding /PTC); fan cowl with canopy.



Installation and operation

The unit is installed in a vertical position. The maximum permissible level of fluid is 20 mm beneath the mounting flange (cf. following drawing).

Dry running is not permitted. Before startup, fill the pump with fluid for pumping. There is only limited support for short-term operation without such fluid during the feeding operation.

Operation against closed valve is possible.

Direction of rotation: to the left (counterclockwise) as viewed from above looking down on the ventilation side of the motor.

Options

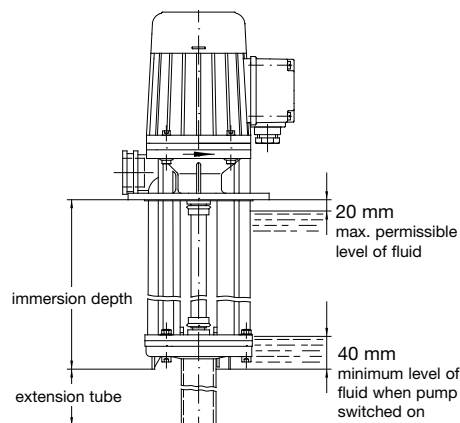

Model with extension tube
if immersion depth deviates from standard.

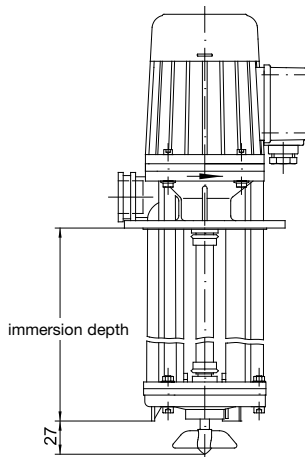

Model with agitator blades
to mix the liquid and distribute the temperature.
(Please note: higher power required)

Order example

PRG 6-170
PRG E 6-170
 Model _____
 Single-phase AC current _____
 Size _____
 Immersion depth t _____

Please indicate electrical parameters, e.g. 230/400 V, 50 Hz.

When ordering spare parts, always indicate the 10-place serial number (see motor rating plate).

Characteristics for 50 Hz

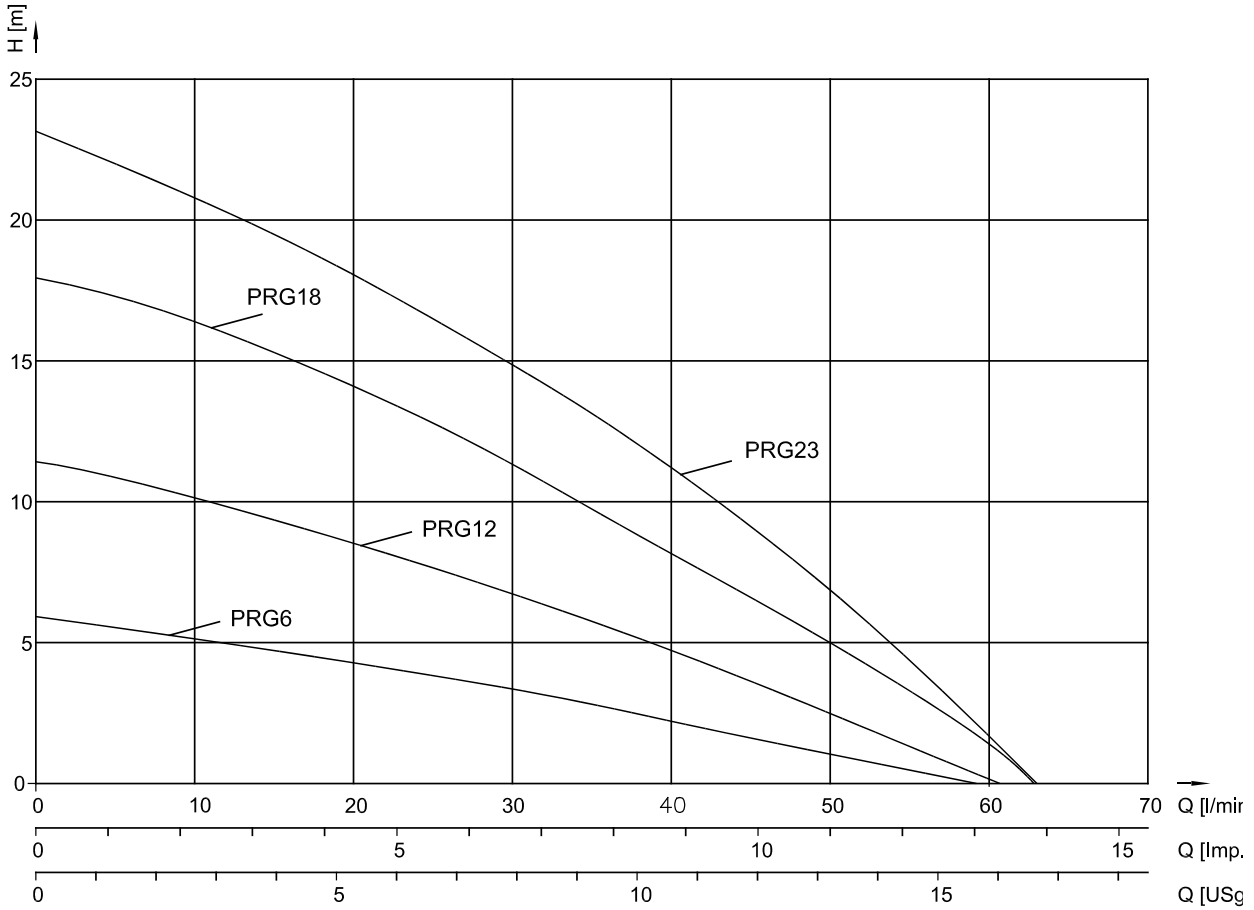

The data apply to fluids with a viscosity of 1 mm²/s at a density of 1 kg/dm³

		Three phase operation					Electrical data		Single-phase operation				
Model	Rated power [kW]	Rated voltage Δ/Y [V]	Rated frequency [Hz]	Rated current Δ/Y [A]	Rated speed [rpm]	Noise level *) [dB (A)]	Model	Rated power [kW]	Rated voltage ⊥ [V]	Rated frequency [Hz]	Rated current ⊥ [A]	Rated speed [rpm]	BC [μF]
PRG6 1-stage	0.06	230/400	50	0.38/0.22	2773	44	PRGE6 1-stage	0.06	230	50	0.56	2817	3
PRG12 2-stage	0.12	230/400	50	0.71/0.41	2637	45	PRGE12 2-stage	0.18	230	50	1.36	2840	6
PRG18 3-stage	0.18	230/400	50	0.87/0.5	2812	48	PRGE18 3-stage	0.35	230	50	1.8	2700	8
PRG23 4-stage	0.37	230/400	50	1.73/1	2667	49	PRGE23 4-stage	0.35	230	50	1.8	2700	8

*) to DIN EN 60034-9/5.96

Characteristics for 60 Hz

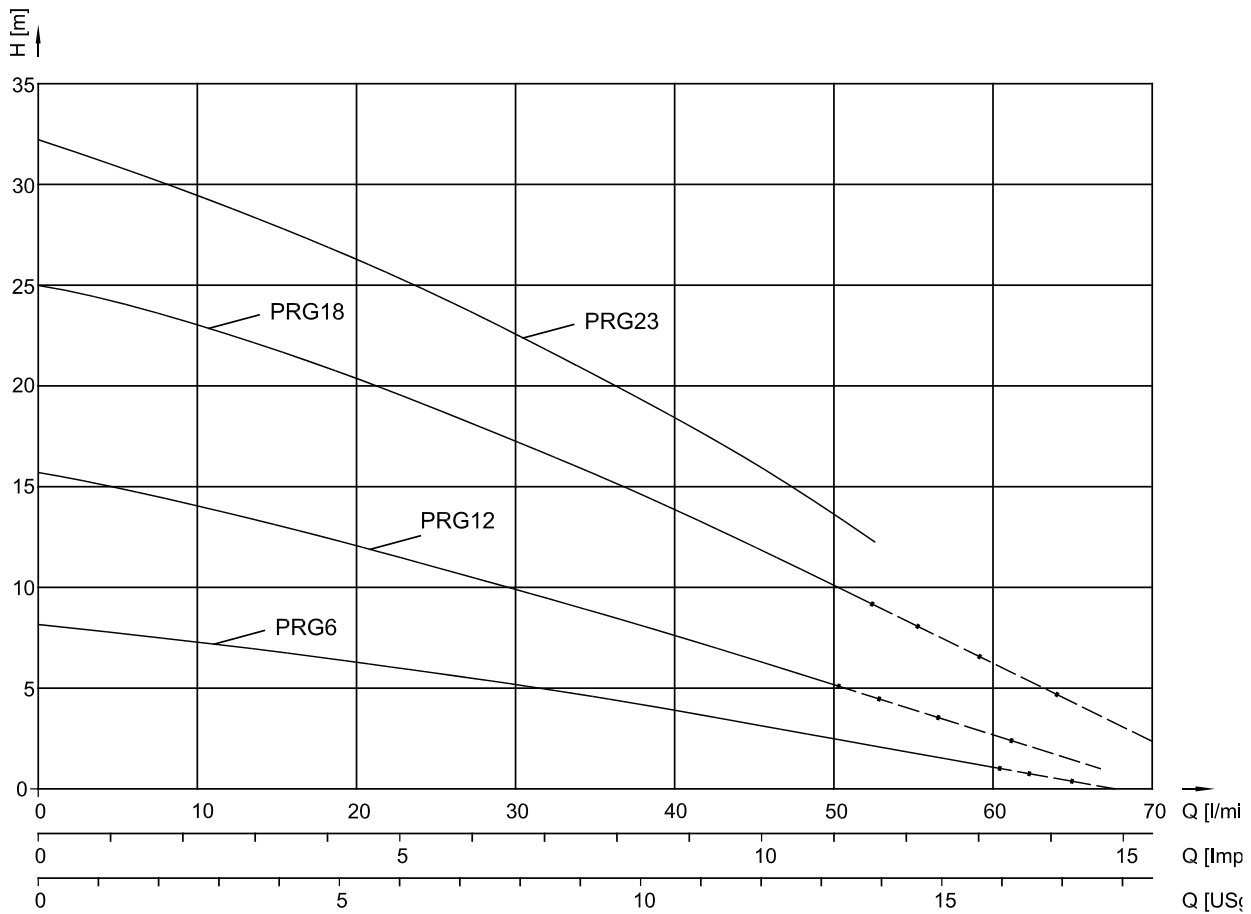

----- Extended performance range in single-phase operation.

The data apply to fluids with a viscosity of 1 mm²/s at a density of 1 kg/dm³

Three phase operation							Electrical data		Single-phase operation					
Model	Rated power [kW]	Rated voltage Δ/Y [V]	Rated frequency [Hz]	Rated current Δ/Y [A]	Rated speed [rpm]	Noise level *) [dB (A)]	Model	Rated power [kW]	Rated voltage ⊥ [V]	Rated frequency [Hz]	Rated current ⊥ [A]	Rated speed [rpm]	BC [μF]	
PRG6 1-stage	0.09	255/440	60	0.42/0.24	3257	45	PRGE6 1-stage	0.09	230	60	0.68	3247	2	
PRG12 2-stage	0.16	255/440	60	0.74/0.43	3158	46	PRGE12 2-stage	0.22	230	60	1.35	3430	6	
PRG18 3-stage	0.25	255/440	60	0.99/0.57	3350	50	PRGE18 3-stage	0.35	230	60	2	3220	6	
PRG23 4-stage	0.37	255/440	60	1.49/0.86	3329	51	PRGE23 4-stage	0.35	230	60	2	3220	6	

*) to DIN EN 60034-9/5.96

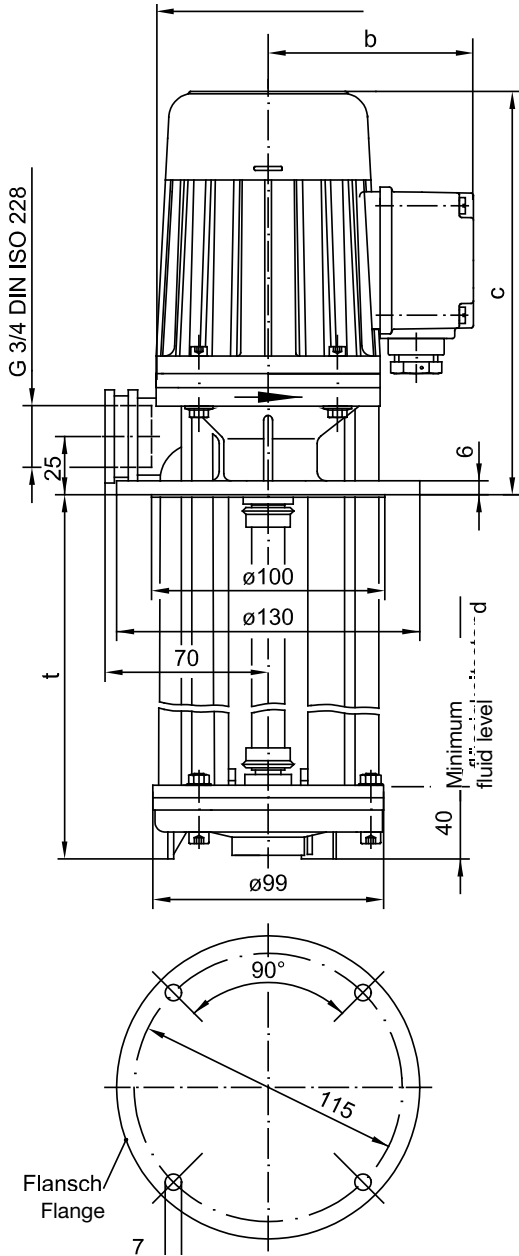

Dimensions and weights						
Model	t [mm]	weight [kg]	ø a	b *)	c	ventilated motors
PRG(E)6 1-stage	120	2.8	96	88	173	x
	140	3.1				
	170					
	220					
	270					
PRG(E)12 2-stage	140	2.9 (4.4)	96 (120)	88 (98)	173 (197)	x
	160	3.3 (4.8)				
	190					
	240					
	290					
PRG(E)18 3-stage	170	4.5	120	98	197	x
	190	4.9				
	220					
	270					
	320					
PRG(E)23 4-stage	200	4.8	120	98	197	x
	220	5.0				
	250					
	300					

*) Dimension "b" is increased by +20 mm in the case of CSA and USA designs or if thermistor-type motor protection is provided.

Standard ventilated motors come without a canopy. If necessary – observe the respective safety regulations and laws applying to machinery guards –, the motors can be supplied with a canopy at extra charge. Dimension "c" is then increased by about 14 mm.

Please note:

All equipment may only be installed and/or assembled by qualified personnel. Observe existing safety regulations. To avoid errors please consult our operating instructions.

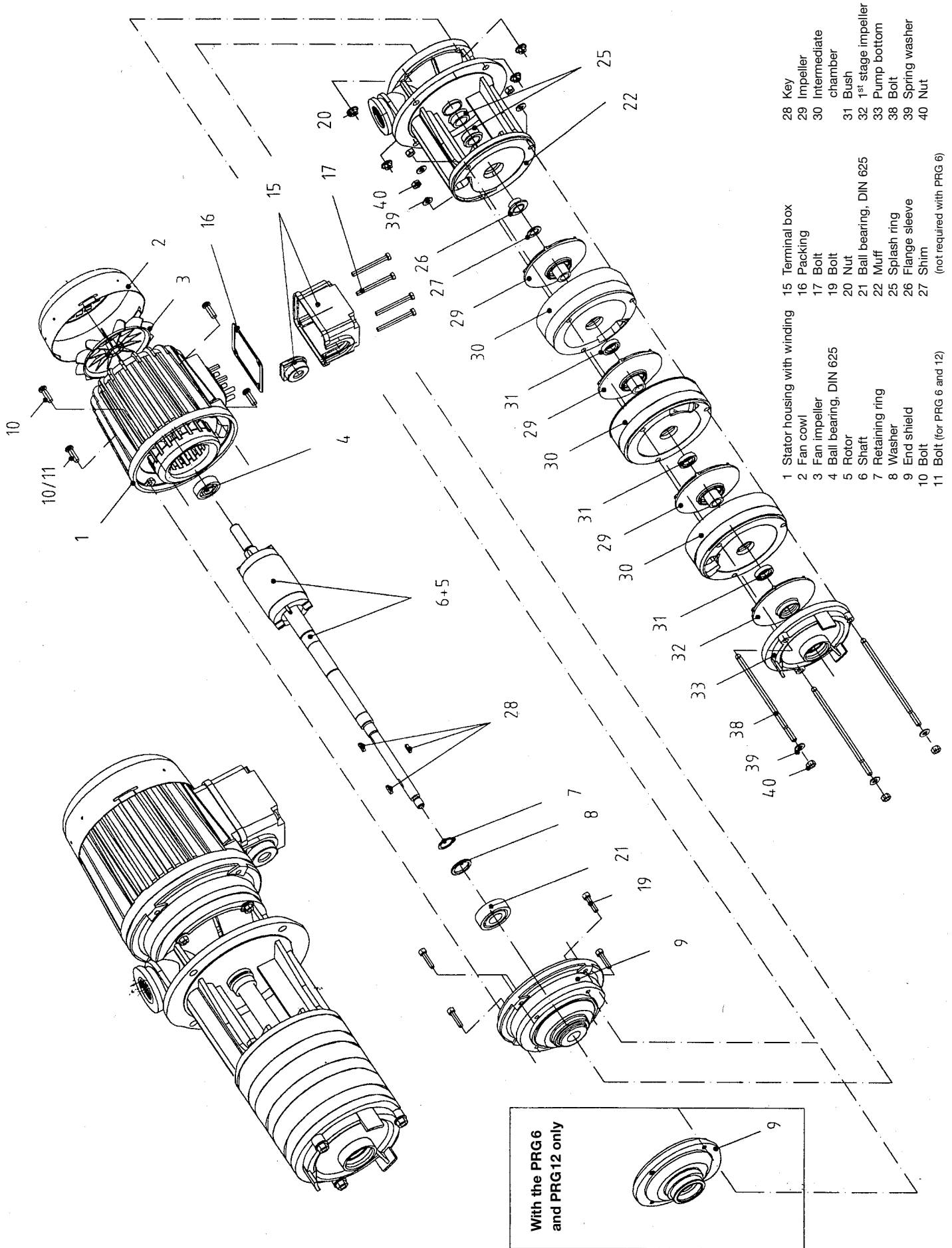

+49 (0)30 72002-261
by fax for the right pump

Sender company, city, person to contact

Date: _____

Operating area: _____ **Quantity:** _____

Working point

Delivery head [m]: _____ Delivery rate [l/min]: _____

Delivery medium

Type: _____ Temperature range [°C]: _____

Density [kg/dm³]: _____ Viscosity at operating temperature [mm²/s]: _____

pH value: _____ Chemical analysis (separate page if necessary): _____

Solids content [ppm]: _____ Grain size [µm]: _____

Special characteristics: _____

Immersion depth [mm]: _____

Material specifications/recommendations (if no delivery medium chem. specified)

Housing: _____ Impeller: _____

Shaft: _____ Seals: _____

Accessories: _____

Electrical parameters

Europe Δ/Y 230/400 V, 50 Hz ⊥ 230 V, 50 Hz Δ 400 V, 50 Hz

USA Δ/Y 265/460 V, 60 Hz YY/Y 230/460 V, 60 Hz (option)

Japan Δ 200 V, 50 Hz Δ 200-220 V, 60 Hz

Other Δ/Y 230/400 V, 50/60 Hz

Additional electrical parameters: _____

Insulation class: F.B _____ Type of enclosure IEC 34: IP 55 _____

Ambient temperature [°C] (if >40 °C): _____

Options

Motor protection (thermistor in winding/PTC): _____ Fan cowl, with canopy: _____

Industrial connectors (DESINA): _____ Frequency converter operation: _____

Special operating conditions: _____

Additional information: _____

We would like to have brochures on:

- | | | |
|---|---|---|
| <input type="checkbox"/> Centrifugal pumps of high-tech plastic | <input type="checkbox"/> Centrifugal pumps of metal | <input type="checkbox"/> Centrifugal pumps: PX modular system |
| <input type="checkbox"/> Screw pumps: LMP | <input type="checkbox"/> Flameproof centrifugal pumps | <input type="checkbox"/> Block pumps |