

HySense®



Sensors for Fluid Measuring Technology

Limitation of liability

The information contained in this catalog has been examined carefully. Nevertheless it is possible that printing or other errors are contained. Therefore we do not take any liability for the correctness of the contained information. They must not be regarded as warranted characteristics, only the product descriptions contained in our offers are decisive.

We reserve all changes due to the technical development and improvement of our products. All prior catalogs lose their validity.

The data contained in this catalog have to be seen as average values and not binding hints. They can be used for constructional purposes in a limited way, only. Please ask for our technical data sheets and construction helps.

Since the use of our products is subject to your responsibility, you will have to check their fitness for the desired application in any case.

All deliveries are carried out solely on the basis of our conditions of sales and delivery. They can be accessed on our homepage www.hydrotechnik.com in the section „Impressum“.

Contents

Continuity and Innovation	4
Quality – our number one priority	5
You will never walk alone	6
HySense® – Sensors for all applications	7
HySense® PR: Pressure sensors	8
HySense® PS: Pressure switches	21
HySense® Q: Volume flow rate sensors	23
HySense® QG: Gear flow sensors	25
HySense® QT: Turbine flow sensors	30
HySense® QO: Oval gear flow sensors	46
HySense® QL: Load valves	49
HySense® TE: Temperature sensors	54
HySense® TP: Twin sensor for temperature and pressure	58
HySense® RS: Rotational speed sensors	61
HySense® PO: Position sensors	63
HySense® FO: Force sensors	65
HySense® TQ: Torque sensors	71
HySense® VB: Vibration sensors	73
HySense® AC: Accessories and replacement parts	76

Please visit us our website www.hydrotechnik.com for more information about us and our product range.

Continuity and Innovation

Information is everything, especially when it comes to complex machinery and installations. Accurate information allows you to monitor condition, quality and performance thereby helping you to prevent catastrophic failures or breakdowns.

For decades, Hydrotechnik has focused on simplifying and improving the detection, collection and evaluation of information from hydraulic installations. We are the inventors of the MINIMESS testpoint and innovators in hydraulic diagnosis. We offer a comprehensive product range to suit a wide variety of applications.

As a streamlined, medium size company, Hydrotechnik's great strength is our ability to develop bespoke or adapted products to fulfill our customers needs, providing you with swift and cost effective customized solutions.

By using modern tools and methods of product design, construction and production, we are able to react quickly to customers' wishes and market developments.



Many of the sensors in this catalogue can be connected to the wide range of Hydrotechnik dataloggers and systems. The icon shown indicates that this is the case. Sensors equipped with ISDS (Intelligent Sensor Detection System) developed for our dataloggers and measuring instruments can be seen in our „Measuring Technology” catalogue which can be downloaded from www.hydrotechnik.com or be obtained from your local Hydrotechnik distributor.



Quality – Our number one priority



For Hydrotechnik, 'Quality without Compromise' is not just a statement. It is a working reality. All areas of the company adhere to maintaining ISO9001 standards, certification of which was awarded in 1996.

To ensure maximum quality control, Hydrotechnik practices the highest standards of manufacturing at our works in Limburg, Germany. Starting with metal working on CNC machines, assembly with modern automated machines through to manual production using highly qualified workers, everything is done to achieve the renowned Hydrotechnik standard of quality.

Where in-house production is not possible, we work with well-known suppliers. When choosing our supply partners, we do not just look at cost but we insist on the ability to achieve our priority of quality. Strict control of the supplied components ensures that the products fully comply with our quality standards.



Condition and thickness of surface coatings are measured using x-ray technology

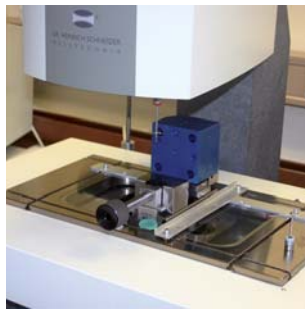

Tactile sensors with ultra-high precision check the size accuracy of a component



Test technician Bernd Zey executes a surface testing of delivered parts



5 µm is the allowed tolerance for these gear wheels



Temperature sensors are calibrated using several test installations



Test technician Robert Rinkart calibrates a pressure sensor by loading it with high-precision weights



Using the latest technology, turbine flow meters and ...



... gear flow meters are tested and calibrated ...



... with the greatest accuracy ensuring precise measuring results.

You will never walk alone

For Hydrotechnik, customer relations do not end with the purchase of a product.

We offer an efficient, reliable and highly-qualified maintenance, repair and calibration service that helps you maintain the value of your Hydrotechnik product.

Calibration



Hydrotechnik runs a calibration laboratory accredited by DKD for the measurands pressure and volume flow. We offer factory calibrations for further measurands, or collaborate with other calibration bodies.

We recommend the regular re-calibration of all sensors, especially volume flow sensors.

Maintenance

With regular qualified maintenance you get the certainty that sensors and measuring instruments function perfectly and maintain accurate measuring results.

We inspect sensors and measuring instruments from Hydrotechnik or other companies in the shortest possible time to reduce the unavoidable off times to a minimum.

Repair

Hydrotechnik products have a very high quality level and are designed for a long life. If damage occurs, we repair reliably, fast and at a reasonable cost.

HySense® – Sensors for all applications

HySense is the new name for all sensors made by Hydrotechnik. It is synonymous with quality without compromise and with unlimited reliability.

Many features are integrated into the new names, as shown below:

The new systematic naming of the sensors indicates the sensor type.

PR 100

Measurand

The two letters at the beginning of the model name indicate the sensor type:

PR	pressure	QL	load valves
PS	pressure switch	RS	rotational speed
TE	temperature	TQ	torque
TP	pressure and temperature	PO	position
QG	volume flow (gear)	FO	force
QT	volume flow (turbine)	VB	vibration
QO	volume flow (oval wheel)	AC	accessories

Model series

The first digit of the model name indicates the model series. The current model series are numbered consecutively starting with 1.

Measurand-specific identifier

The second digit of the model name is reserved for an identifier that indicates either the type of the connecting plug (for all sensors, except volume flow sensors), or the output signal of the sensor (for volume flow sensors).

The coding is shown at the beginning of each section of this catalogue.

Special versions

The third digit of the model name indicates special versions of the sensor:

5	explosion-proof
6	CAN output signal
7	high-temperature
8	increased IP protection
9	DESINA conform version

Pressure is a central factor in fluid technology. By measuring the pressure, basic settings in systems and installations can be made and it is also very important for diagnosis of the complete system.

Hydrotechnik offers a broad range of piezo-resistive sensors where the deformation of a metal membrane

influences electrical resistance which can be used to determine pressure values and dynamic changes.

The offered sensors are separated into three product families:



HySense PR 1xx (former product name HT-PD)

Proven standard sensors for industrial use, equipped with a measuring cell made of high-grade steel. Special versions for explosive environments, with increased IP protection and CAN output signal.



HySense PR 2xx

High-precision sensor with very small dimensions. Ideal for all applications with reduced installation space.



HySense PR 3xx (former product name PR 15)

Our top model for measuring tasks requiring the highest accuracy. We use a piezo-resistive silicon chip protected from environmental influences by a high-grade steel casing. A thin flexible metal membrane in the casing separates the transmission fluid from the medium.

Connector versions

The second digit of the model name indicates the connector type:

0	6 pole device connector, M16 x 0,75
1	5 pole device connector, M16 x 0,75
2	5 pole device connector, M12 x 1
3	4 pole device connector, M12 x 1
4	4 pole device connector, EN 175301-803 type A, Pg9
5	4 pole device connector, EN 175301-803 type C, Pg7
8	other connector versions
9	open wires

HySense PR 130*

4 pole device connector, M12 x 1



Dimensions

A 4 pole device connector
 B ISO 228 – G ¼ A
 C Restrictor insert Ø 0.6 for measuring ranges
 > 0 ... 60 bar (0 ... 6.0 MPa)
 D Profile seal acc. to DIN 3869, FKM
 E SW 22

Qualities	
Measuring principle	piezo-resistive (poly-cristalline silicon thin film structure on high-grade steel membrane)
Pressure type	relative pressure
Output signal	4 ... 20 mA / 0 ... 10 VDC
Electrical measuring connector	4 pole device connector, M12 x 1
Mechanical connection thread	ISO 228 – G ¼ A
Sealing material	profile seal ring acc. to DIN 3869, FKM
Protection type (EN 60529 / IEC 529)	IP 67 (when connector is screwed)
Casing material	non-corrosive high-grade steel
Membrane material	non-corrosive high-grade steel
Tightening torque	40 Nm (± 5 Nm)
Weight	~ 85 g

Pin assignment	4 ... 20 mA (two wires)	0 ... 10 V (three wires)
	1 + Ub / signal +	1 + Ub
	2 free	2 free
	3 – Ub / signal –	3 – Ub / signal – / GND
	4 free	4 Signal +

Measuring range		Order number	
bar	MPa	4 ... 20 mA	0 ... 10 V
-1 ... 6	-0.1 ... 0.6	3403-32-I5.37S	3403-32-I5.39S
0 ... 10	0 ... 1.0	3403-26-I5.37S	3403-26-I5.39S
0 ... 25	0 ... 2.5	3403-40-I5.37S	3403-40-I5.39S
0 ... 60	0 ... 6.0	3403-21-I5.37S	3403-21-I5.39S
0 ... 100	0 ... 10	3403-16-I5.37S	3403-16-I5.39S
0 ... 250	0 ... 25	3403-17-I5.37S	3403-17-I5.39S
0 ... 400	0 ... 40	3403-15-I5.37S	3403-15-I5.39S
0 ... 600	0 ... 60	3403-18-I5.37S	3403-18-I5.39S
0 ... 1.000	0 ... 100	3403-29-I5.37S	3403-29-I5.39S

Common technical data on page 14. Further output signals on request.
 Measuring ranges > 1000 ... 4000 bar (100 ... 400 MPa) on request.

*: former product name HT-PD

HySense PR 140*

4 pole device connector, DIN EN 175301-803 type A, Pg9



Dimensions

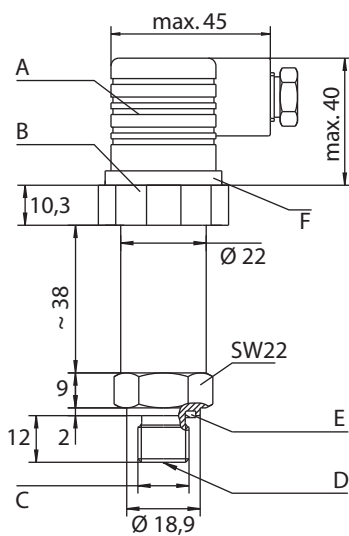

- A Contact box, Typ EN 175301-803, type A
 B Device connector SW 33,5
 C ISO 228 – G $\frac{1}{4}$ A
 D Restrictor insert \varnothing 0.6 for measuring ranges > 0 ... 60 bar (0 ... 6.0 MPa)
 E Profile seal acc. to DIN 3869, FKM
 F Profile seal

Qualities

Measuring principle	piezo-resistive (poly-crystalline silicon thin film structure on high-grade steel membrane)
Pressure type	relative pressure
Output signal	4 ... 20 mA / 0 ... 10 VDC
Electrical measuring connector	4 pole device connector, DIN EN 175301-803, type A, Pg9
Mechanical connection thread	ISO 228 – G $\frac{1}{4}$ A
Sealing material	profile seal ring acc. to DIN 3869, FKM
Protection type (EN 60529 / IEC 529)	IP 65 (with connecting cable \varnothing 6 ... 8 mm)
Casing material	non-corrosive high-grade steel
Membrane material	non-corrosive high-grade steel
Tightening torque	40 Nm (\pm 5 Nm)
Weight	~ 117 g

Pin assignment

	4 ... 20 mA (two wires)	0 ... 10 V (three wires)
	1 + Ub / signal +	1 + Ub
	2 – Ub / signal –	2 – Ub / signal – / GND
	3 free	3 Signal +

Measuring ranges		Order number	
bar	MPa	4 ... 20 mA	0 ... 10 V
-1 ... 6	-0.1 ... 0.6	3403-32-D1.37S	3403-32-D1.39S
0 ... 10	0 ... 1.0	3403-26-D1.37S	3403-26-D1.39S
0 ... 25	0 ... 2.5	3403-40-D1.37S	3403-40-D1.39S
0 ... 60	0 ... 6.0	3403-21-D1.37S	3403-21-D1.39S
0 ... 100	0 ... 10	3403-16-D1.37S	3403-16-D1.39S
0 ... 250	0 ... 25	3403-17-D1.37S	3403-17-D1.39S
0 ... 400	0 ... 40	3403-15-D1.37S	3403-15-D1.39S
0 ... 600	0 ... 60	3403-18-D1.37S	3403-18-D1.39S
0 ... 1.000	0 ... 100	3403-29-D1.37S	3403-29-D1.39S

Common technical data on page 14. Further output signals on request.
 Measuring ranges > 1000 ... 4000 bar (100 ... 400 MPa) on request.

*: former product name HT-PD



HySense PR 150*

4 pole device connector, DIN EN 175301-803 type C, Pg7



Dimensions

A: 4 pole device connector, Typ EN 175301-803, type C
 B: ISO 228 – G $\frac{1}{4}$ A
 C: Restrictor insert \varnothing 0.6 for measuring ranges > 0 ... 60 bar (0 ... 6.0 MPa)
 D: Profile seal acc. to DIN 3869, FKM
 E: Profile seal

Qualities	
Measuring principle	piezo-resistive (poly-cristalline silicon thin film structure on high-grade steel membrane)
Pressure type	relative pressure
Output signal	4 ... 20 mA / 0 ... 10 VDC
Electrical measuring connector	4 pole device connector, DIN EN 175301-803, type C, Pg7
Mechanical connection thread	ISO 228 – G $\frac{1}{4}$ A
Sealing material	profile seal ring acc. to DIN 3869, FKM
Protection type (EN 60529 / IEC 529)	IP 65 (with connecting cable \varnothing 4,5 ... 6 mm)
Casing material	non-corrosive high-grade steel
Membrane material	non-corrosive high-grade steel
Tightening torque	40 Nm (\pm 5 Nm)
Weight	~ 97 g

Pin assignment	4 ... 20 mA (two wires)	0 ... 10 V (three wires)
		1 + Ub / signal + 2 - Ub / signal - 3 free

Measuring ranges		Order number	
bar	MPa	4 ... 20 mA	0 ... 10 V
-1 ... 6	-0.1 ... 0.6	3403-32-D5.37S	3403-32-D5.39S
0 ... 10	0 ... 1.0	3403-26-D5.37S	3403-26-D5.39S
0 ... 25	0 ... 2.5	3403-40-D5.37S	3403-40-D5.39S
0 ... 60	0 ... 6.0	3403-21-D5.37S	3403-21-D5.39S
0 ... 100	0 ... 10	3403-16-D5.37S	3403-16-D5.39S
0 ... 250	0 ... 25	3403-17-D5.37S	3403-17-D5.39S
0 ... 400	0 ... 40	3403-15-D5.37S	3403-15-D5.39S
0 ... 600	0 ... 60	3403-18-D5.37S	3403-18-D5.39S
0 ... 1.000	0 ... 100	3403-29-D5.37S	3403-29-D5.39S

Common technical data on page 14. Further output signals on request.
 Measuring ranges > 1000 ... 4000 bar (100 ... 400 MPa) on request.

*: former product name HT-PD



Dimensions

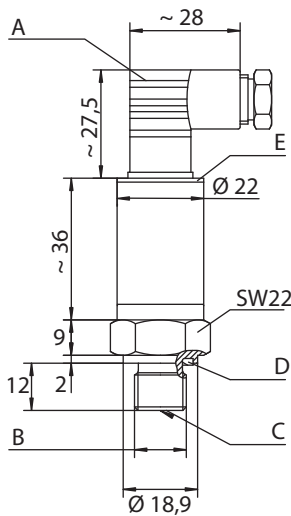

- A 4 pole device connector EN 175301-803, type C
 B ISO 228 – G $\frac{1}{4}$ A
 C Restrictor insert Ø 0.6 for measuring ranges
 > 0 ... 60 bar (0 ... 6.0 MPa)
 D Profile seal acc. to DIN 3869, FKM
 E Profile seal

Qualities

Measuring principle	piezo-resistive (poly-crystalline silicon thin film structure on high-grade steel membrane)
Pressure type	relative pressure
Output signal	4 ... 20 mA
Electrical measuring connector	4 pole device connector, DIN EN 175301-803, type C, Pg7
Mechanical connection thread	ISO 228 – G $\frac{1}{4}$ A
Sealing material	Profile seal ring acc. to DIN 3869, FKM
Protection type (EN 60529 / IEC 529)	IP 65 (with connecting cable Ø 4.5 ... 6 mm)
Casing material	non-corrosive high-grade steel
Membrane material	non-corrosive high-grade steel
Tightening torque	40 Nm (\pm 5 Nm)
Weight	~ 100 g
Ex-approval	Ex II 2G
Explosion protection	EEx ia IIC T4
Approval number	IBExU 06 ATEX 1159

Pin assignment

4 ... 20 mA (two wires)

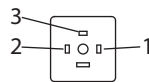

- 1 free
 2 – Ub / signal – / GND
 3 + Ub / signal +

Measuring range		Order number
bar	MPa	4 ... 20 mA
-1 ... 1	-0.1 ... 0.1	3X03-20-03.37
0 ... 25	0 ... 2.5	3X03-40-03.37
0 ... 60	0 ... 6.0	3X03-21-03.37
0 ... 100	0 ... 10	3X03-16-03.37
0 ... 250	0 ... 25	3X03-17-03.37
0 ... 400	0 ... 40	3X03-15-03.37
0 ... 600	0 ... 60	3X03-18-03.37
0 ... 1.000	0 ... 100	3X03-29-03.37

Common technical data on page 14. Further output signals on request.
 Measuring ranges > 1000 ... 2000 bar (100 ... 200 MPa) on request.



Dimensions

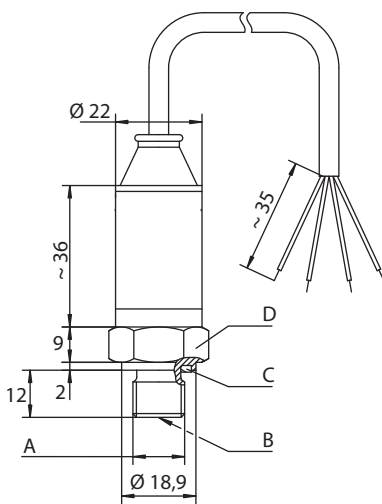

- A ISO 228 – G $\frac{1}{4}$ A
- B Restrictor insert \varnothing 0.6 for measuring ranges > 0 ... 60 bar (0 ... 6.0 MPa)
- C Profile seal acc. to DIN 3869, FKM
- D SW 22

Qualities

Measuring principle	piezo-resistive (poly-cristalline silicon thin film structure on high-grade steel membrane)
Pressure type	relative pressure
Output signal	4 ... 20 mA / 0 ... 10 VDC
Electrical measuring connector	open ends, 4 wires, connection cable 1.5 m
Mechanical connection thread	ISO 228 – G $\frac{1}{4}$ A
Sealing material	profile seal ring acc. to DIN 3869, FKM
Protection type (EN 60529 / IEC 529)	IP 68 K
Casing material	non-corrosive high-grade steel
Membrane material	non-corrosive high-grade steel
Tightening torque	40 Nm (\pm 5 Nm)
Weight	\sim 120 g

Wire assignment

Wire color	4 ... 20 mA (two wires)	0 ... 10 V (three wires)
white	free	Signal +
black	– Ub / signal –	– Ub / signal – / GND
green	free	free
red	+ Ub / signal +	+ Ub

Measuring range		Order number	
bar	MPa	4 ... 20 mA	0 ... 10 V
-1 ... 6	-0.1 ... 0.6	3403-32-D6.37S	3403-32-D6.39S
0 ... 10	0 ... 1.0	3403-26-D6.37S	3403-26-D6.39S
0 ... 25	0 ... 2.5	3403-40-D6.37S	3403-40-D6.39S
0 ... 60	0 ... 6,0	3403-21-D6.37S	3403-21-D6.39S
0 ... 100	0 ... 10	3403-16-D6.37S	3403-16-D6.39S
0 ... 250	0 ... 25	3403-17-D6.37S	3403-17-D6.39S
0 ... 400	0 ... 40	3403-15-D6.37S	3403-15-D6.39S
0 ... 600	0 ... 60	3403-18-D6.37S	3403-18-D6.39S
0 ... 1.000	0 ... 100	3403-29-D6.37S	3403-29-D6.39S

Common technical data on page 14. Further output signals on request.
Measuring ranges > 1000 ... 4000 bar (100 ... 400 MPa) on request.

*: former product name HT-PD

Common technical data

The technical data shown here is valid for the sensors in the HySense® PR 1xx range, mentioned on the previous pages:

- PR 130
- PR 140
- PR 150
- HT-PDX-20 (PR 155)
- PR 190

Technical data	PR 130 / PR 140 / PR 150 / PR 190	HT-PDX-20
Overload range	1.5 x nominal pressure	
Burst pressure	3 x nominal pressure	
Signal type	Two wire analog (4 ... 20 mA), three wire analog (0 ... 10 VDC)	
Supply voltage U_b		
... at 4 ... 20 mA	10 ... 30 VDC	30 V
... at 0 ... 10 VDC	12 ... 32 VDC	–
Current consumption	6.5 mA	50 mA
Overvoltage protection	32 VDC	
Error limit (of final value)	comprises the influences non-linearity, hysteresis, repeatability, zero-point- and span error	
... at +22 °C (room temperature)	± 0.5 %	
... at -15 ... +85 °C	< ± 1.0 %	
... at +85 ... +100 °C	< ± 2.5 %	
... at -40 ... -15 °C	< ± 2.5 %	
Temperature error (-20 ... +80 °C)	< ± 0,03 %/°C	
Compensation temperature range	-40 ... +100 °C	
Non-linearity	< ± 0.4 % of final value	
Reproducibility	< ± 0.1 % of final value	
Hysteresis	< ± 0.1 % of final value	
Long-term stability	< ± 0.1 % of final value/year	
Response time	< = 1 ms (10 ... 90 %)	
Frequency range	< = 1 kHz	
Isolation resistance	min. 100 MΩ	
Total resistance	$R_g = (U_b - 10 \text{ V}) / 20 \text{ mA}$ (at output signal 4 ... 20 mA)	
Load resistance	$R_L = > 5 \text{ k}\Omega$ (at output signal 0 ... 10 VDC)	
Number of load cycles	> 10 x 10 ⁶	
Medium temperature	-40 ... +125 °C	
Environmental temperature	-40 ... +105 °C (short term +125 °C)	-40 ... +85 °C
Storage temperature	-40 ... +125 °C	
EMV test	EN 50081-2, EN 50082-2	
Vibrational stability	5 mm 10 ... 32 Hz, 20 g 32 ... 500 Hz, DIN EN 60068-2-6	
Shock stability	50 g (11 ms half-sine)	
Mounting orientation	arbitrary	



5 pole device connector, M12 x 1



Dimensions

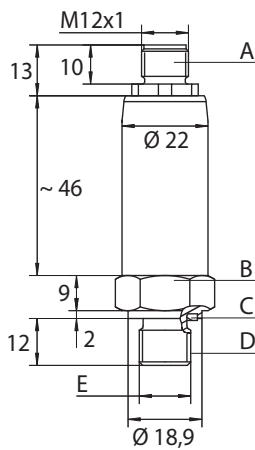

- A 5 pole device connector, M12 x 1
 B SW 22
 C Profile seal ring acc. to DIN 3869, FKM
 D Restrictor insert \varnothing 0.6
 E ISO 228 G $\frac{1}{4}$ A

Qualities

Measuring principle	piezo-resistive (poly-cristalline silicon thin film structure on high-grade steel membrane)
Pressure type	relative pressure
Output signal	CANopen
Electrical measuring connector	5 pole device connector, M12 x 1
Mechanical connection thread	ISO 228 – G $\frac{1}{4}$ A
Sealing material	profile seal ring acc. to DIN 3869, FKM
Protection type (EN 60529 / IEC 529)	IP 67 (with screwed connector)
Casing material	non-corrosive high-grade steel
Membrane material	non-corrosive high-grade steel
Tightening torque	40 Nm (\pm 5 Nm)
Weight	~ 100 g
CAN bus	LSS slave function
Baud rate	10 ... 500 kBaud (settable)
CAN interface	acc. to DIN 11898

Pin assignment

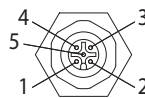

Pin assignment	CANopen
1	CAN_SHLD
2	CAN_V+
3	CAN_GND
4	CAN_H
5	CAN_L

Measuring range

Order number

bar	MPa	CANopen
0 ... 100	0 ... 10	3403-16-D2.60
0 ... 400	0 ... 40	3403-15-D2.60
0 ... 600	0 ... 60	3403-18-D2.60

*: former product name HT-PD

Technical data

Technical data	PR 126
Overload range	2 x nominal pressure
Burst pressure	3 x nominal pressure
Signal type	CANopen, digital
Supply voltage U_b	12 ... 27 VDC
Current consumption	10 ... 30 mA, depends on CAN bus load
Overvoltage protection	± 40 VDC
Error limit (of final value)	comprises the influences non-linearity, hysteresis, repeatability, zero-point- and span error
... at +22 °C (room temperature)	± 0.5 %
... at -15 ... +85°C	± 0.5 %
... at +85 ... +100°C	± 1.0 %
... at -40 ... -15°C	± 1.0 %
Compensation temperature range	-15 ... +85 °C
Non-linearity	$< \pm 0.2$ % of final value
Reproducibility	$< \pm 0.1$ % of final value
Hysteresis	$< \pm 0.1$ % of final value
Long-term stability	$< \pm 0.1$ % of final value/year
Response time	≤ 1 ms (0 ... 90 %)
Frequency range	≤ 1 kHz
Isolation resistance	> 100 MOhm
Number of load cycles	1×10^7
Medium temperature	-40 ... +105 °C
Environmental temperature	-40 ... +105 °C
Storage temperature	-40 ... +125 °C
EMV test	EN 50081-2 and EN 50082-2
Vibrational stability	IEC 68-2-6 and IEC 68-2-36, 20 g
Mounting orientation	arbitrary

HySense PR 280

Miniature pressure sensor

This sensor is ideal for applications where very low weight and minimized dimensions are required (e.g. in regulating valves).



Dimensions

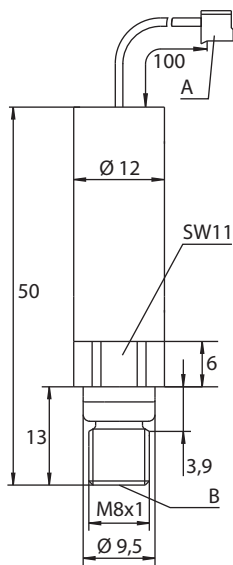

- A Connector box PHR-3 by JST
- B Restrictor drill hole Ø 0.6

Qualities

Measuring principle	piezo-resistive (poly-cristalline silicon thin film structure on high-grade steel membrane)
Pressure type	relative pressure
Output signal	0.5 ... 4.5 VDC
Electrical measuring connector	connector box JST PHR-3
Mechanical connection thread	M8 x 1
Sealing material	O ring FKM
Protection type (EN 60529 / IEC 529)	IP 00
Casing material	1.4571
Membrane material	non-corrosive high-grade steel
Tightening torque	8 Nm (± 2 Nm)
Weight	~ 22 g

Pin assignment

Connector box PHR-3	0.5 ... 4.5 V DC (three wires)
	Pin 1 = Ub
	Pin 2 = GND
	Pin 3 = signal

Ø D	Measuring range		Order number
	bar	MPa	
mm			0.5 ... 4.5 V DC
15	0 ... 20	0 ... 2	34B3-27-03.49
12	0 ... 100	0 ... 10	34B3-16-03.49
	0 ... 160	0 ... 16	34B3-19-03.49
	0 ... 250	0 ... 25	34B3-17-03.49
	0 ... 400	0 ... 40	34B3-15-03.49

Due to EMC requirements, it is necessary to install the sensor in a capsuled metal casing.

Technical data

Technical data	PR 280
Overload range	2 x nominal pressure
Burst pressure	4 x nominal pressure
Signal type	three wire
Supply voltage U_b	12 ... 30 VDC
Current consumption	< 10 mA
Error limit (of final value)	comprises the influences non-linearity, hysteresis, repeatability, zero-point- and span error
... at +22 °C (room temperature)	± 0.5 %
... at -15 ... +85°C	± 0.5 %
... at +85 ... +100°C	± 1.0 %
... at -40 ... -15°C	± 1.0 %
Compensation temperature range	0 ... +80 °C
Non-linearity	< ± 0.2 % of final value
Reproducibility	< ± 0.05 % of final value
Hysteresis	< ± 0.1 % of final value
Long-term stability	< ± 0.2 % of final value/year
Response time	< = 1 ms
Frequency range	> 1 kHz
Isolation resistance	> 100 MΩ
Load resistance	2.3 kΩ
Number of load cycles	> 1 x 10 ⁷
Medium temperature	-20 ... +90 °C
Environmental temperature	-40 ... +125 °C
Storage temperature	-40 ... +140 °C
EMV test	DIN EN 61000-4-2 / -3 / -4 / -6 / -8
Vibrational stability	1 mm oscillation way (10 ... 50 Hz) 20 g (20 ... 2,000 Hz)
Shock stability	50 g (6 ms half-sine)
Mounting orientation	arbitrary



5 pole device connector, M16 x 0.75

This pressure sensor has a very fast response time ≥ 1 ms, very low noise qualities and optimized accuracy.

Dimensions

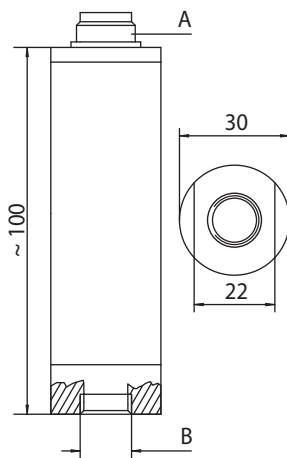

- A 5 pole device connector, M16 x 0.75
B ISO 228 G $\frac{1}{4}$ inside thread

Qualities

Measuring principle	piezo-resistive (silicon chip in stainless steel casing filled with transmission fluid)
Pressure type	relative pressure
Output signal	0 ... 20 mA / 4 ... 20 mA
Electrical measuring connector	5 pole device connector, M16 x 0.75
Mechanical connection thread	ISO 228 – G $\frac{1}{4}$ inside thread
Sealing material	FKM (pressure measuring cell)
Protection type (EN 60529 / IEC 529)	IP 40
Casing material	1.4104, 1.4301
Membrane material	1.4435
Tightening torque	40 Nm (± 5 Nm)
Weight	~ 120 g

Pin assignment

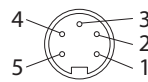

Pin assignment	4 ... 20 mA (two wires)	0 ... 20 mA (three wires)
Pin 1 = – Ub / signal –	Pin 1 = signal +	
Pin 2 = free	Pin 2 = – Ub / signal – / GND	
Pin 3 = + Ub / signal +	Pin 3 = + Ub	
Pin 4 = free	Pin 4 = free	
Pin 5 = free	Pin 5 = free	

Measuring ranges

Order number

bar	MPa	4 ... 20 mA	0 ... 20 mA
-1 ... 6	-0.1 ... 0.6	3403-32-71.37A	3403-32-71.33A
0 ... 60	0 ... 6.0	3403-21-71.37A	3403-21-71.33A
0 ... 200	0 ... 20	3403-10-71.37A	3403-10-71.33A
0 ... 400	0 ... 40	3403-15-71.37A	3403-15-71.33A
0 ... 600	0 ... 60	3403-18-71.37A	3403-18-71.33A
0 ... 1.000	0 ... 100	3403-29-71.37A	3403-29-71.33A

*: former product name PR 15

Technical data

Technical data	PR 310
Overload range	1.5 x measuring range
Burst pressure	2.5 x measuring range
Signal type	two wire 4 ... 20 mA, three wire 0 ... 20 mA
Supply voltage U_b	6.5 ... 30 VDC
Current consumption	three wire without signal < 10 mA
Overload protection	36 VDC
Error limit (of final value)	comprises the influences non-linearity, hysteresis, repeatability, zero-point- and span error
... at +22 °C (room temperature)	$\pm 0,25 \%$
... at -20 ... +80°C	$< \pm 3\%$
Compensation temperature range	-20 ... +80 °C
Non-linearity	$> 0.1 \text{ MPa} < \pm 0.25 \%$ of final value
Reproducibility	$< \pm 0.25 \%$ of final value
Hysteresis	$> 0.1 \text{ MPa} < \pm 0.25 \%$ of final value
Long-term stability	$< = 0.1 \%$ of final value
Response time	1 ms (0 ... 98 %)
Frequency range	$< = 1 \text{ kHz}$
Isolation resistance	min. 10 MOhm
Total resistance	$R_g = U_b / 0,020$ (at output signal 4 ... 20 mA) $R_g = U_b / 0,030$ (at output signal 0 ... 20 mA)
Load resistance three wires	$R_L = U_b - 6 \text{ V} / 0.020 < = 500 \text{ Ohm}$
Load resistance two wires	$R_L = U_b - 10 \text{ V} / 0.020 < = 700 \text{ Ohm}$
Number of load cycles	$> 1 \times 10^6$
Medium temperature	-20 ... +80 °C
Environmental temperature	-20 ... +80 °C
Storage temperature	-20 ... +85 °C
EMV test	EN 50081-2, EN 50082-2
Vibrational stability	10 g (5 ... 2,000 Hz), IEC 60068-2-6
Shock stability	50 g (11 ms), IEC 60068-2-29
Mounting orientation	arbitrary

Electronic pressure switch



The HySense® pressure switches are available as standard and to DESINA conformity. They are equipped with a 4-digit, 7-segment display, its 7 mm high red numbers can be read easily in all conditions. The device can be rotated by 280°, is made of zinc die casting with polyester cover foil and powder-coated with crimson color (RAL 3004).

- Measuring instrument with digital pressure display
- One/two threshold switches, separately programmable (exceedance / undercut of a pre-defined pressure)
- Analog output (presentation of the pressure profile)

Dimensions

A ISO 228-G $\frac{1}{4}$ A
 B with integrated resistor insert \varnothing 0.6 for measuring ranges > 0 ... 60 bar
 C profile seal ring acc. to DIN 3869, FKM

Qualities	
Measuring principle	piezo-resistive
Pressure type	relative pressure
Output signal PS 120	4 ... 20 mA / 0 ... 20 mA (settable)
Output signal PS 129	4 ... 20 mA
Electrical measuring connector	5 pole device connector, M12 x 1
Mechanical connection thread	ISO 228 – G $\frac{1}{4}$ A
Sealing material	FKM
Protection type (EN 60529 / IEC 529)	IP 67 (only with screwed cable box)
Switching outputs	2 Mosfet high side switch PNP
Contact function	closer / opener
Switching voltage (VDC)	Supply voltage minus 1.5 VDC
Switching current	max. 0.7 A / switch
Short-circuit current	2.4 A / switch
Casing material	GD-ZnAl4Cu1
Membrane material	1.4542
Tightening torque	40 Nm (\pm 5 Nm)
Weight	~ 350 g

Pin assignment	PS 120	PS 129 (DESINA)
		Pin 1 = + Ub
Pin 2 = S2		Pin 2 = analog OUT
Pin 3 = 0 V / GND		Pin 3 = 0 V / GND
Pin 4 = S1		Pin 4 = S1
Pin 5 = analog OUT		Pin 5 = free

Measuring range		Order number	
bar	MPa	PS 120	PS 129 (DESINA)
0 ... 25	0 ... 2.5	3160-10-40.01	3160-11-40.02
0 ... 100	0 ... 10	3160-10-16.01	3160-11-16.02
0 ... 250	0 ... 25	3160-10-17.01	3160-11-17.02
0 ... 400	0 ... 40	3160-10-15.01	3160-11-15.02

*: former product name Multi-EPC

Technical data

Technical data	PS 120 / PS 129			
Measuring range	0 ... 25 bar	0 ... 100 bar	0 ... 250 bar	0 ... 400 bar
Overload range	75 bar	150 bar	750 bar	
Burst pressure	150 bar	300 bar	1.500 bar	
Signal type	analog output power source (output signals 4 ... 20 mA and 0 ... 20 mA)			
Supply voltage U_b	15 ... 30 VDC, nominal 24 VDC (ripple < 5 % V_{ss} of U_b)			
Current consumption	< 100 mA			
Overload protection	protected against short-circuits, reverse-polarity and overload			
Error limit (of final value)	comprises the influences non-linearity, hysteresis, repeatability, zero-point- and span error			
... at +23 °C (room temperature)	± 0.5 %			
Temperature coefficient	< 0.2 % of final value /10 °K			
Compensation temperature range	-10 ... +80 °C			
Non-linearity and hysteresis	± 0.5 % of final value			
Reproducibility	± 0.2 % of final value			
Long-term stability	± 0.2 % of final value/year			
Response time	> = 10 ms			
Frequency range	< 100 Hz			
Isolation resistance	> = 1 MOhm			
Total resistance	depends on type (current consumption)			
Load resistance	$R_L < 500 \text{ Ohm}$			
Number of load cycles	> 10×10^6			
Medium temperature	-20 ... +85 °C			
Environmental temperature	-20 ... +85 °C			
Storage temperature	-30 ... +100 °C			
EMV test	noise emission acc. to EN 61000-6-4, noise stability acc. to EN 61000-6-2			
Vibrational stability	10 g (5 ... 2,000 Hz), IEC 60068-2-6			
Shock stability	50 g (11 ms), IEC 60068-2-29			
Mounting orientation	arbitrary			

HySense Q

Volume flow sensors

Measuring of volume flow rates is very important for diagnosis and condition monitoring of fluid-technical systems. Hydrotechnik offers four product types, each providing its own specific qualities and advantages.



Gear volume flow sensors (displacement principle)

- Outstanding measuring accuracy, low error limits
- High viscosity independence, broad measuring range for each type
- High medium temperatures and working pressures up to 630 bar
- Linearisation in the measuring instrument
- Detection of flow direction, arbitrary mounting position and connectors
- Measuring of quantities possible (metering)
- Viscosity min. 5 mm²/s (cSt)



Turbine volume flow sensors (flow principle)

- Good reproducibility, low error limits
- Linearisation in the measuring instrument
- Low flow resistance, suitable for lots of media
- Short response time
- Low weight, small dimensions and arbitrary mounting position
- High media temperature and working pressure up to 400 bar
- Small delta-P
- Media viscosity up to 270 mm²/s (cSt)



Oval wheel volume flow sensors (displacement principle)

- High measuring accuracy
- Suitable for lots of media
- Low weight
- Good life expectancy
- Small dimensions



Load valves with turbine volume flow sensors

- Simulation of load conditions
- Pump tests, e.g. recording of characteristic curves
- Volume flow sensor, load valve and test points for pressure and temperature in a single unit

HySense Q

Volume flow sensors

Output signal

The second digit of the model name indicates the output signal of the sensor:

0	digital
1	analog

Important tips for all volume flow sensors

- Each volume flow sensor is delivered with a calibration certificate. Please keep this safe.
- We recommend a re-calibration of the sensor every 1 or 2 years. Please use the Hydrotechnik calibration service. Please do not forget to send the calibration certificate with the sensor when ordering calibration services.
- Multiple calibrations for different viscosities are possible for all volume flow sensors!



HySense QG 100* / QG 110*



Gear volume flow sensor



Delivery with f/l-converter for output signal 4...20 mA***

The volume flow sensor QG 100 with frequency output signal allows detection of the medium flow direction and impulse duplication when used with Hydrotechnik measuring instruments. A possible application is the positioning during cylinder traverse paths.

Qualities	
Measuring principle	displacement
Viscosity range	10 ... 500 mm ² /s (cSt)
Medium temperature	-20 ... +120 °C
Environmental temperature	max. +80 °C
Storage temperature	-20 ... +85 °C
Output signal	frequency (rectangle) / 4 ... 20 mA
Supply voltage U _b	12 ... 24 VDC
Electrical measuring connector	5 pole device connector, M16 x 0.75
Protection type (EN 60529 / IEC 529)	IP 40
Tightening torque	< 0.5 Nm, thread pin (clamping piece) T 3362000
Calibration viscosity	30 mm ² /s (cSt)
Material casing cover	1.4305
Material middle / bottom part	0.7060
Material sealings	FKM
Material gear wheels	1.7131
Suitable measuring cable	MK 01

Pin assignment	QG 100 (frequency)	QG 110 (4 ... 20 mA)
	Pin 1 = signal +	Pin 1 = signal +
	Pin 2 = - U _b / signal - / GND	Pin 2 = signal - / GND
	Pin 3 = + U _b	Pin 3 = + U _b
	Pin 4 = free	Pin 4 = free
	Pin 5 = free	Pin 5 = free

Measuring range	Non-linearity	Geometric gear volume	Allowed working pressure		Impulses per liter	Hydraulic connector	Error limit*
			bar	MPa			
0.05 ... 5.0	± 0.5 %	~ 0.191	630	63	5,250	ISO 228-G ¹ / ₄	± 0.5 %
0.2 ... 30.0**		~ 0.609	160	16	1,640	ISO 228-G ³ / ₈	
0.2 ... 30.0	± 0.4 %	~ 2.222	420	42	450	ISO 228-G ³ / ₄	± 0.4 %
0.7 ... 70.0					100	SAE-Flansch 1 ¹ / ₄	± 0.5 %
3 ... 300	± 0.5 %	~ 8.750					

*: for QG 100 and factory calibrated viscosity
 **: casing material AlCuMgPb F37
 ***: for QG 110 additional ± 0.2 % of final value (error of f/l-converter)
 Factory standard calibration for mineral oil at 30 cSt.
 Other calibration viscosity optional.

Measuring range	Order number / weight			
	QG 100 (frequency)	g	QG 110 (4 ... 20 mA)	g
0.05 ... 5.00	3143-02-35.030	3,000	3185-02-35.030	3,155
0.2 ... 30.0	3843-03-35.030**	1,481	3885-03-35.030**	1,641
0.2 ... 30.0	3143-03-35.030	4,074	3185-03-35.030	4,186
0.7 ... 70.0	3143-04-35.030	9,000	3185-04-35.030	9,100
3 ... 300	3143-05-35.030	32,330	3185-05-35.030	32,490

*: former product name GFM

Dimensions

QG 100

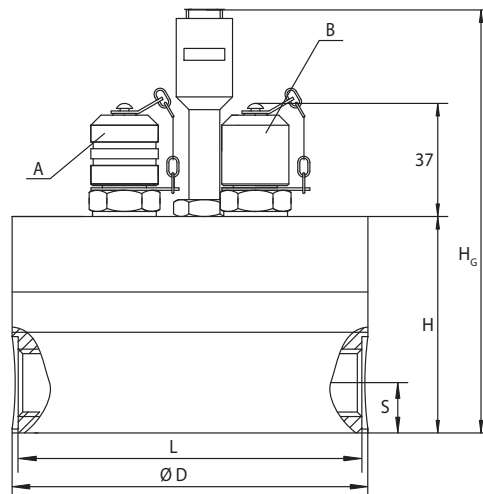

- A MINIMESS® p/T test point, series 1620
- B MINIMESS® test point, series 1620

QG 110

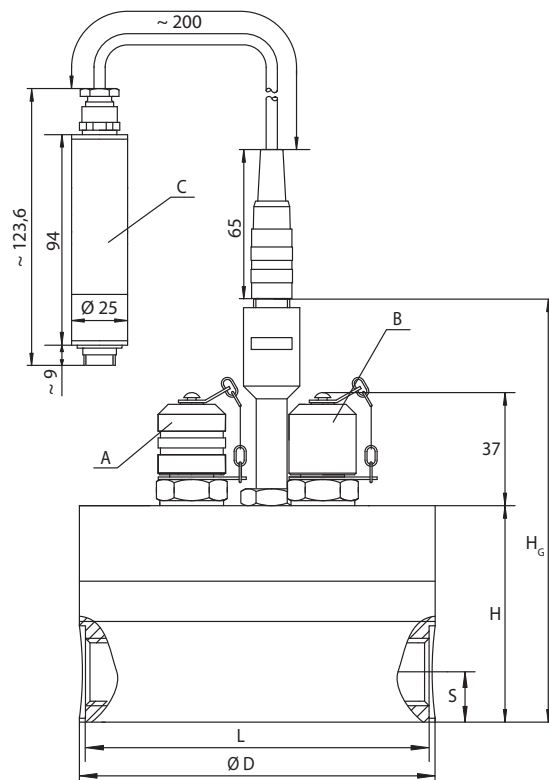

- A MINIMESS® p/T test point, series 1620
- B MINIMESS® test point, series 1620
- C f/l-converter

Measuring range	D	H	H _G	L	S	Type
l/min	mm					see below
0.05 ... 5.00	96	59	125	93	13	A
0.2 ... 30.0	106	67	133	102,5	15	A
0.7 ... 70.0	136	93	153	131	20	A
3 ... 300	210	145	190	210	42	B

QG 100 / QG 110

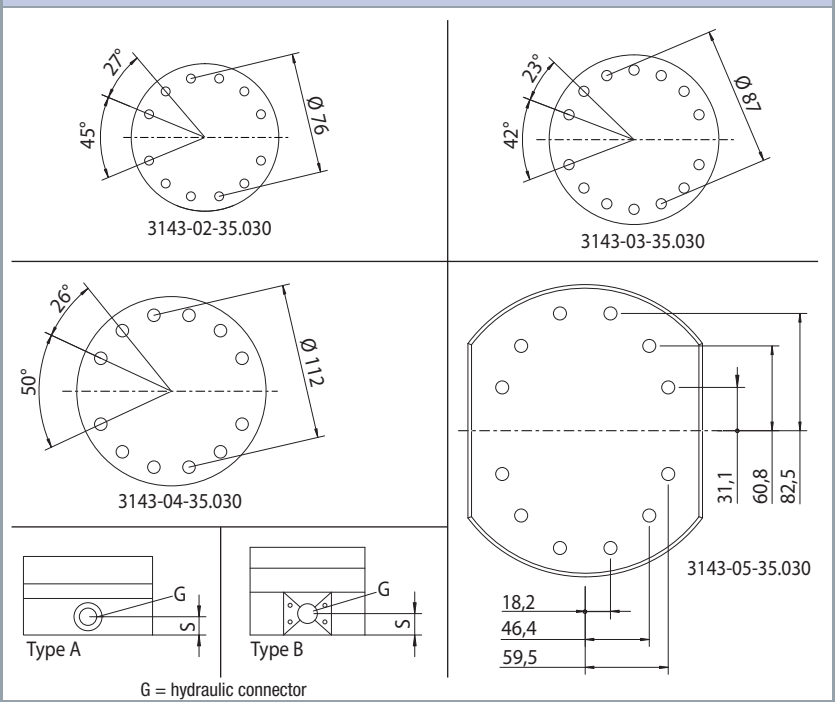

Q = 0.05 ... 5 l/min

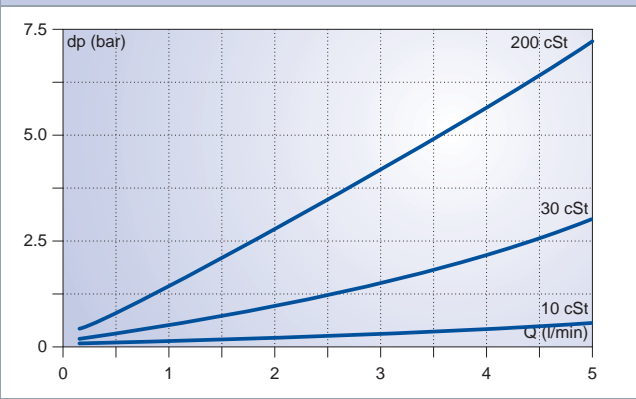

Q = 0.2 ... 30 l/min

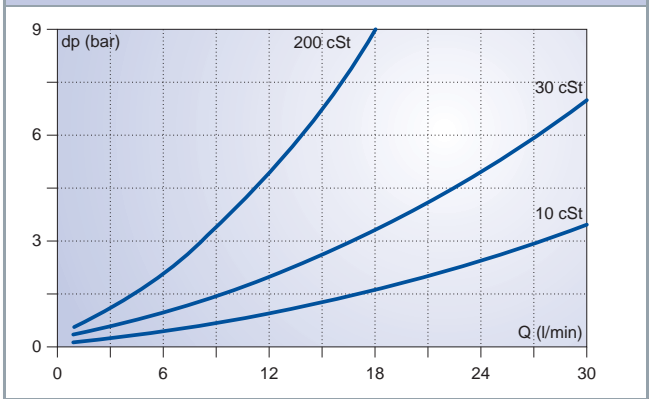

Q = 0.7 ... 70 l/min

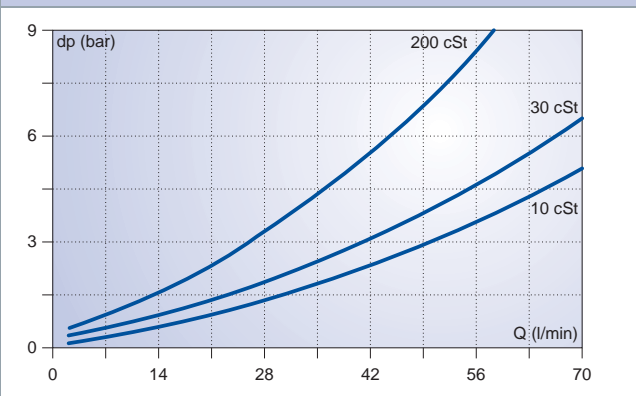

Q = 3 ... 300 l/min

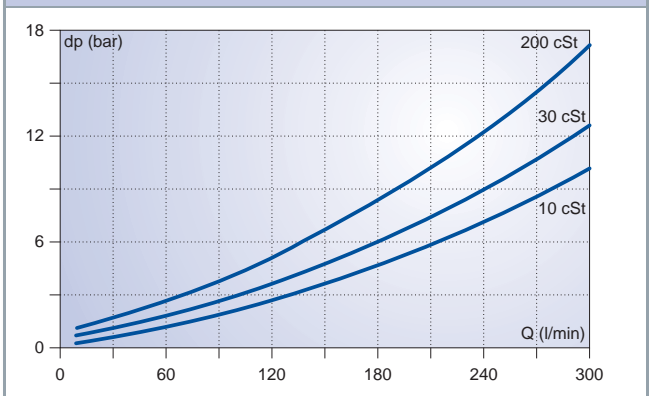

HySense QG 107*

Gear volume flow sensor for high-temperature applications



Qualities	
Measuring principle	displacement
Viscosity range	10 ... 500 mm ² /s (cSt)
Medium temperature	-20 ... +160 °C
Environmental temperature	max. +50 °C (amplifier)
Storage temperature	-20 ... +85 °C
Output signal	frequency (rectangle)
Supply voltage U _b	10 ... 30 VDC
Electrical measuring connector	4 pole device connector, M12 x 1
Protection type (EN 60529 / IEC 529)	IP 64
Tightening torque	8 Nm (± 2 Nm)
Calibration viscosity	30 mm ² /s (cSt)
Material casing cover	1.4305
Material middle / bottom part	0.7060
Material sealings	FKM
Material gear wheels	1.7131
Suitable measuring cable	customer-specific

Pin assignment	Frequency
	Pin 1 = + U _b
	Pin 2 = signal
	Pin 3 = - U _b / GND
	Pin 4 = free

Measuring range	Geometric gear volume	Allowed working pressure		Impulses per liter	Hydraulic connector	Error limit*
		bar	MPa			
l/min	cm ³					of current value
0.2 ... 30.0	~ 0.609	630	63	1,640	ISO 228-G ³ /8	± 0.5 %
0.7 ... 70.0	~ 2.222	420	42	450	ISO 228-G ³ /4	± 0.4 %

Measuring range	Weight	Order number
l/min	g	
0.2 ... 30.0	3,700	3189-03-35.030
0.7 ... 70.0	8,600	3189-04-35.030

*: former product name GFM

*: for factory calibrated viscosity
Factory standard calibration for mineral oil at 30 cSt. Other calibration viscosities optional.

- A MINIMESS® p/T test point, series 1620
- B MINIMESS® test point, series 1620
- C Frequency sensor, high-temperature version

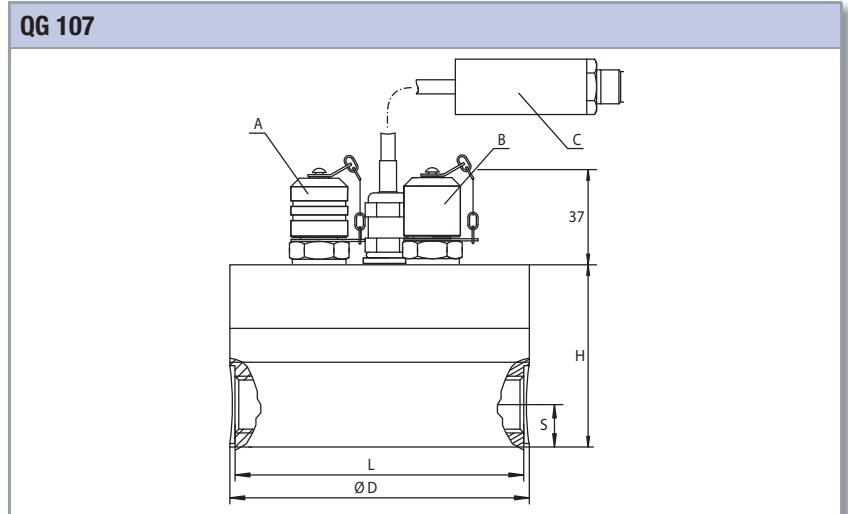

Measuring range	D	H	H _G	L	S	Weight	Type
l/min	mm					g	
0.2 ... 30.0	106	67	133	102.5	15	4,074	A
0.7 ... 70.0	136	93	153	131	20	9,000	A

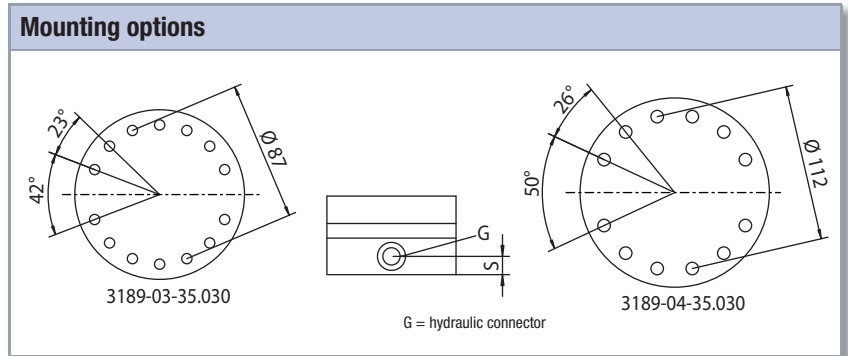

On page 27 you can find the delta-P curves for the volume flow sensors QG 100 / QG 110. These are valid for the sensors QG 107, too.



Turbine volume flow sensor



Precise and proven measuring turbine with inside thread connection acc. to DIN ISO 228, available with digital (frequency, rectangle signal) or analog (4 ... 20 mA) output signal.

The turbines have a factory calibration for mineral oil at 30 cSt, other calibration viscosities are available. You can also order versions with flow measuring in both directions, but detection of the flow direction is not possible.

Qualities

Measuring principle	volume flow
Viscosity range	see order data
Medium temperature	max. +120 °C
Environmental temperature	-20 ... +85 °C
Storage temperature	-20 ... +85 °C
Output signal	frequency (rectangle) / 4 ... 20 mA
Supply voltage U_b	12 ... 24 VDC
Electrical measuring connector	5 pole device connector, M16 x 0.75
Protection type (EN 60529 / IEC 529)	IP 40
Tightening torque	10 Nm (\pm 2 Nm)
Calibration viscosity	30 mm ² /s (cSt)
Material turbine casing	Aluminium AlZnMgCu 1,5
Material turbine wheel	1.4122 (for measuring range 1.0 ... 10 l/min) 1.0718 (for all other measuring ranges)
Material sealings	FKM
Material sensor casing	1.4301
Vibration stability	10 g (5 ... 2000 Hz), IEC 60068-2-6
Shock stability	50 g (11 ms), IEC 60068-2-29
Suitable measuring cable	MK 01

Pin assignment

	QT 100 (frequency)	QT 110 (4 ... 20 mA)
	Pin 1 = signal +	Pin 1 = signal +
	Pin 2 = - U_b / signal - / GND	Pin 2 = signal - / GND
	Pin 3 = + U_b	Pin 3 = + U_b
	Pin 4 = free	Pin 4 = free
	Pin 5 = free	Pin 5 = free

Measuring range	Allowed working pressure		Viscosity range	Error limit*	Order number / weight			
	l/min	bar			MPa	mm ² /s (cSt)	of current value	QT 100 (frequency)
1.0 ... 10.0	420	42	1 ... 30	\pm 2.5 %	31V7-01-35.030	631	31G7-01-35.030	681
7.5 ... 75.0			1 ... 100	\pm 2.5 %	31V7-70-35.030	785	31G7-70-35.030	869
15 ... 300			1 ... 100	\pm 2.5 %	31V7-71-35.030	1,125	31G7-71-35.030	1,206
25 ... 600			350	1 ... 100	\pm 2.0 %	31V7-72-35.030	1,378	31G7-72-35.030

*: for QT 100 and factory calibrated viscosity;
for QT 110 additional \pm 0.2 % of final value (error f/l-converter)

*: former product name RE4

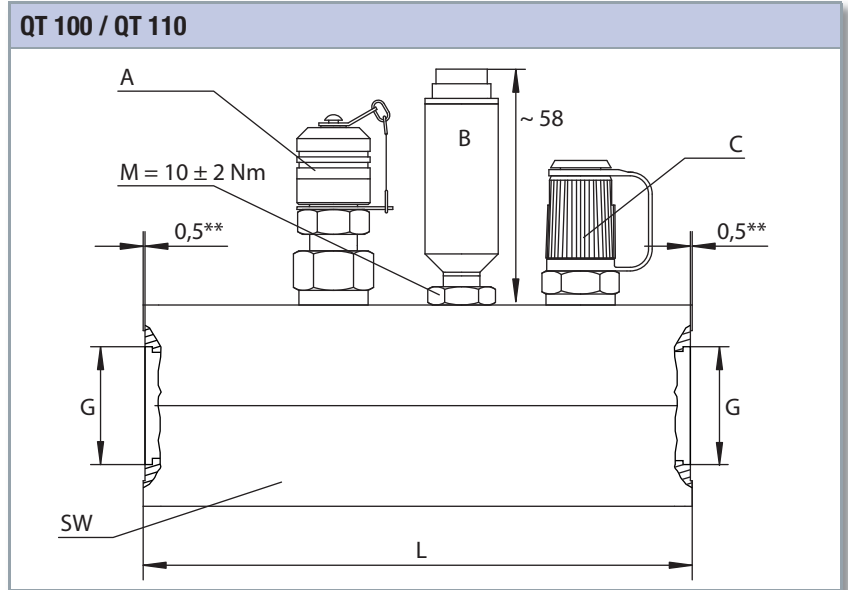

Measuring range	L	SW	G
l/min	mm		
1.0 ... 10.0	120	41	ISO 228-G $\frac{1}{4}$
7.5 ... 75.0	130	46	ISO 228-G $\frac{3}{4}$
15 ... 300	150	55	ISO 228-G1
25 ... 600	174	60	ISO 228-G1 $\frac{1}{4}$

- A MINIMESS® p/T test point for pressure and temperature, series 1620
- B max. tightening torque $M = 10 \pm 2$ Nm
- C inductive sensor / amplifier
- D MINIMESS® test point, series 1620
- H height is appr. 58 mm (for QT 100) or appr. 108 mm (for QT 110)
- ** depth of the spot face



CAN turbine volume flow sensor



A version has been adapted for the CAN bus based on our precise and proven measuring turbine with inside thread connection according to DIN ISO 228.

The turbines are factory calibrated for mineral oil at 30 cSt. Other calibration viscosities are available.

Qualities	
Measuring principle	volume flow
Viscosity range	see order data
Medium temperature	max. +120 °C
Environmental temperature	-20 ... +85 °C
Storage temperature	-20 ... +85 °C
Output signal	CANopen
Supply voltage U_b	8.5 ... 30 VDC
Electrical measuring connector	5 pole device connector, M12 x 1
Protection type (EN 60529 / IEC 529)	IP 67 (screwed)
Tightening torque	10 Nm (\pm 2 Nm)
Calibration viscosity	30 mm ² /s (cSt)
Material turbine casing	Aluminium AlZnMgCu 1,5
Material turbine wheel	1.4122 (for measuring range 1,0 ... 10 l/min) 1.0718 (for all other measuring ranges)
Material sealings	FKM
Material sensor casing	3.1645
Current consumption	max. 50 mA @ 24 VDC
Interface	CANopen (CIA-DS-301)
CAN standard	2.0A (opt. 2.0B)
Transmission rate	20 ... 1.000 kBit/s
Measured frequency (Hz)	bytes 0 ... 3
Measured volume flow (l/min)	bytes 4 ... 7
Resolution	three decimal places
Vibration stability	10 g (5 ... 2000 Hz), IEC 60068-2-6
Shock stability	50 g (11 ms), IEC 60068-2-29
Suitable measuring cable	CAN cable

Pin assignment	CANopen 2.0A
	Pin 1 = CAN_SHLD
	Pin 2 = CAN_V+
	Pin 3 = CAN_GND
	Pin 4 = CAN_H
	Pin 5 = CAN_L

*: former product name RE4

Measuring range	Max. working pressure		Viscosity range	Error limit	Weight	Order number
	l/min	bar				
1 ... 10	420	42	1 ... 30	± 1.0 %	671	31C7-01-35.030
2 ... 75	420	42	1 ... 100	± 0.5 %	859	31C7-70-35.030
9 ... 300	420	42	1 ... 100	± 0.5 %	1,190	31C7-71-35.030
16 ... 600	350	35	1 ... 100	± 0.5 %	1,488	31C7-72-35.030

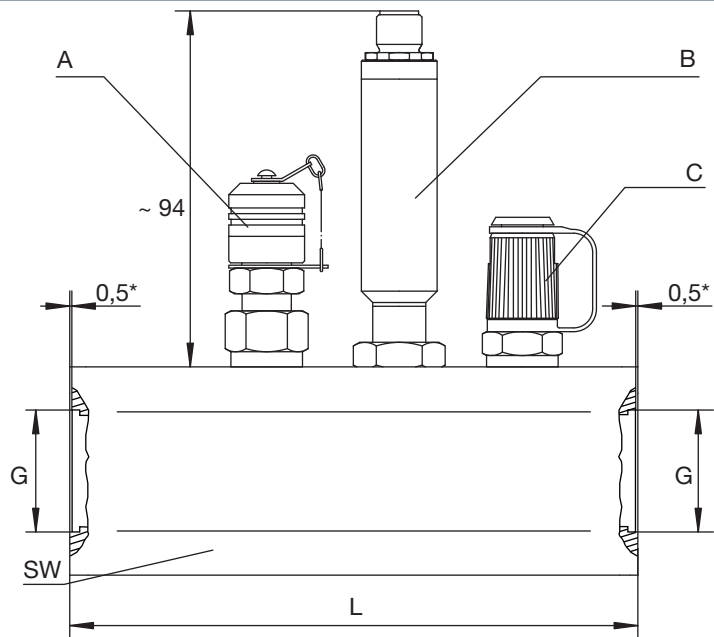
QT 106

- A MINIMESS® p/T test point for pressure and temperature, series 1620
- B inductive sensor / amplifier
- C MINIMESS® test point, series 1620
- * depth of spot face

Measuring range	SW	L	G
l/min		mm	
1 ... 10	41	120	ISO 228-G¼
2 ... 75	46	130	ISO 228-G¾
9 ... 300	55	150	ISO 228-G1
16 ... 600	60	174	ISO 228-G1¼

HySense QT 118*

Turbine volume flow sensor with increased IP protection

NEW



The turbines are factory calibrated for mineral oil at 30 cSt. Other calibration viscosities are available on request.

Qualities	
Measuring principle	volume flow
Viscosity range	see order data
Medium temperature	max. +120 °C
Environmental temperature	-20 ... +85 °C
Storage temperature	-20 ... +85 °C
Output signal	4 ... 20 mA
Supply voltage U_b	12 ... 24 VDC
Electrical measuring connector	device connector 3 pole AMP, acc. to DIN 72585
Protection type (EN 60529 / IEC 529)	IP 69
Tightening torque	10 Nm (\pm 2 Nm)
Calibration viscosity	30 mm ² /s (cSt)
Material turbine casing	Aluminium AlZnMgCu 1,5
Material turbine wheel	1.4122 (for measuring range 1.0 ... 10 l/min) 1.0718 (for all other measuring ranges)
Material sealings	FKM
Material sensor casing	1.4571
Vibration stability	10 g (5 ... 2000 Hz), IEC 60068-2-6
Shock stability	50 g (11 ms), IEC 60068-2-29
Suitable measuring cable	customer-specific

Pin assignment	4 ... 20 mA
	Pin 1 = signal +
	Pin 2 = signal - / GND
	Pin 3 = + U_b

Measuring range	Max. working pressure		Viscosity range	Error limit	Weight	Order number
	l/min	bar				
1.0 ... 10.0	420	42	1 ... 30	\pm 2.5 % of current value	681	31N7-01-35.030
7.5 ... 75.0	420	42	1 ... 100	\pm 2.5 %	869	31N7-70-35.030
15 ... 300	420	42	1 ... 100	\pm 2.5 %	1,206	31N7-71-35.030
25 ... 600	350	35	1 ... 100	\pm 2.0 %	1,498	31N7-72-35.030

*: former product name RE4

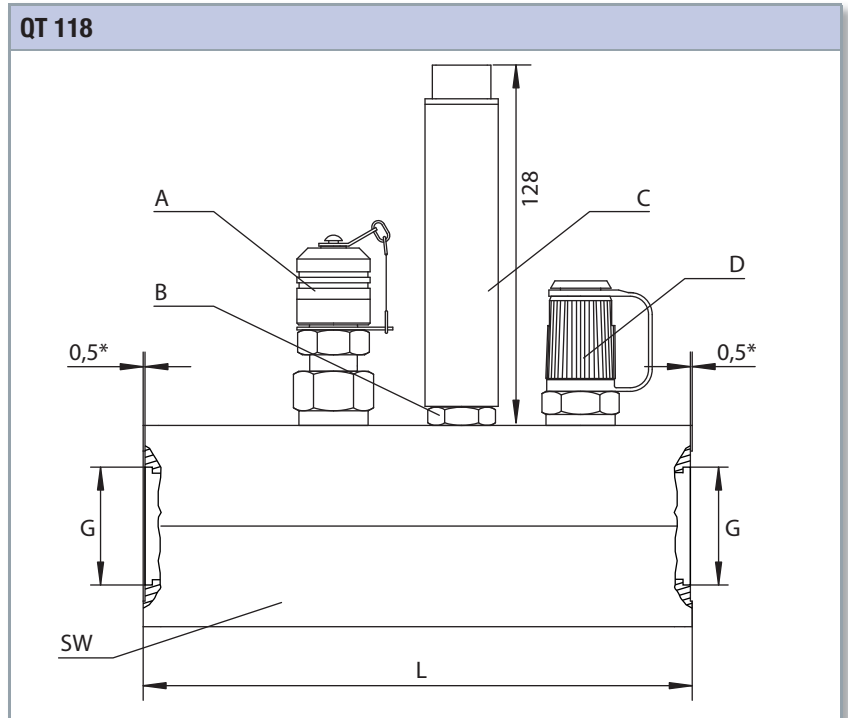

Measuring range	L	SW	G	Error limit*
l/min	mm			%
1.0 ... 10.0	120	41	ISO 228-G $\frac{1}{4}$	± 2.5
7.5 ... 75.0	130	46	ISO 228-G $\frac{3}{4}$	
15 ... 300	150	55	ISO 228-G1	± 2.0
25 ... 600	174	60	ISO 228-G1 $\frac{1}{4}$	

- A MINIMESS® p/T test point for pressure and temperature, series 1620
- B max. tightening torque $M = 10 \pm 2$ Nm
- C inductive sensor / amplifier
- D MINIMESS® test point, series 1620
- * depth of spot face

delta-P curves

The delta-P curves shown here are valid for the volume flow sensors of the HySense® QT 1xx range, shown on the previous pages:

- QT 100
- QT 106
- QT 110
- QT 118

Q = 1.0 ... 10 l/min

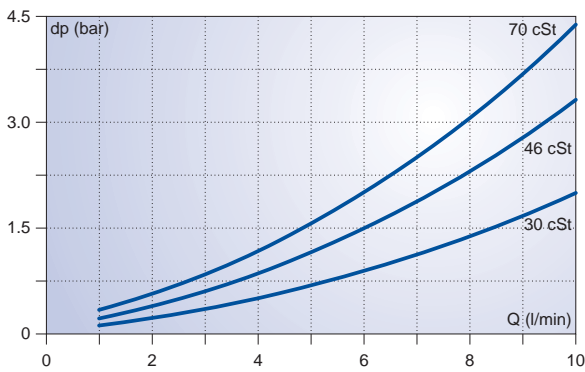

Q = 7.5 ... 75 l/min

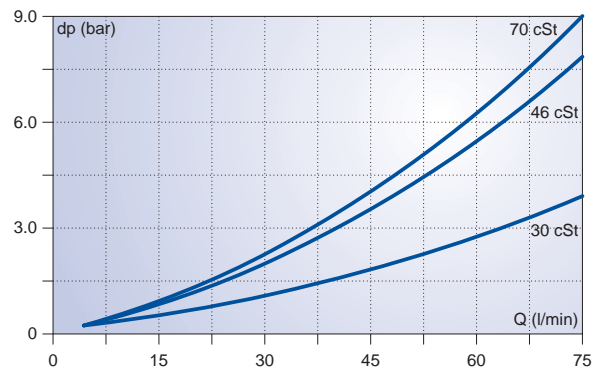

Q = 15 ... 300 l/min

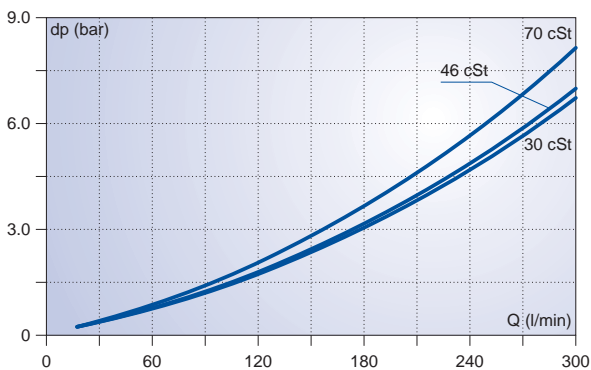

Q = 25 ... 600 l/min

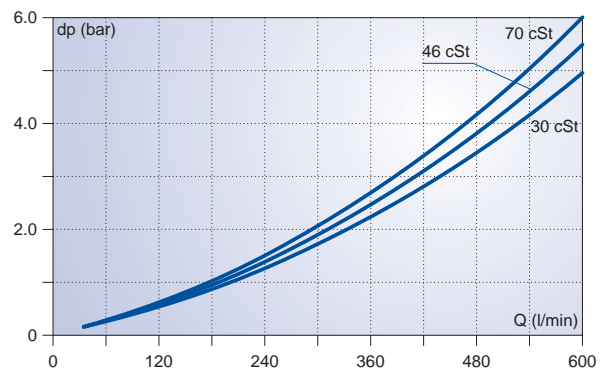



Turbine volume flow sensor



Turbine volume flow sensor with high precision and inside thread connector acc. to DIN ISO 228 for use with water and similar media, preferably.

The turbines are equipped with floating bearings and factory calibrated for water at 1 cSt. Other calibration viscosities are available on request.

Qualities	
Measuring principle	volume flow
Viscosity range	1 ... 10 mm ² /s (cSt)
Medium temperature	max. +120 °C
Environmental temperature	-20 ... +85 °C
Storage temperature	-20 ... +85 °C
Output signal	frequency (rectangle) / 4 ... 20 mA
Supply voltage U _b	12 ... 24 VDC
Error limit*	± 2.5 %
Electrical measuring connector	5 pole device connector, M16 x 0,75
Protection type (EN 60529 / IEC 529)	IP 40
Tightening torque	10 Nm (± 2 Nm)
Calibration viscosity	2,5 mm ² /s (cSt)
Material turbine casing	Edelstahl X12CrNiS18 8 (passiviert)
Material turbine wheel	1.4122 (for measuring range 1.0 ... 10 l/min) 1.0718 (for all other measuring ranges)
Material sealings	FKM
Material sensor casing	1.4301
Suitable measuring cable	MK 01

Pin assignment	QT 200 (frequency)	QT 210 (4 ... 20 mA)
	Pin 1 = signal +	Pin 1 = signal +
	Pin 2 = - U _b / signal - / GND	Pin 2 = signal - / GND
	Pin 3 = + U _b	Pin 3 = + U _b
	Pin 4 = free	Pin 4 = free
	Pin 5 = free	Pin 5 = free

Measuring range	Maximum working pressure		Order number / Weight				
	l/min	bar	MPa	QT 200 (frequency)	Weight (g)	QT 210 (4 ... 20 mA)	Weight (g)
1.0 ... 10.0	420	42		33V7-01-35.001	686	33G7-01-35.001	736
7.5 ... 100	420	42		33V7-77-35.001G	1,926	33G7-77-35.001G	1,980
15 ... 300	420	42		33V7-78-35.001G	3,304	33G7-78-35.001G	3,574
25 ... 600	350	35		33V7-79-35.001G	4,033	33G7-79-35.001G	4,033

*: former product name RE6

Dimensions

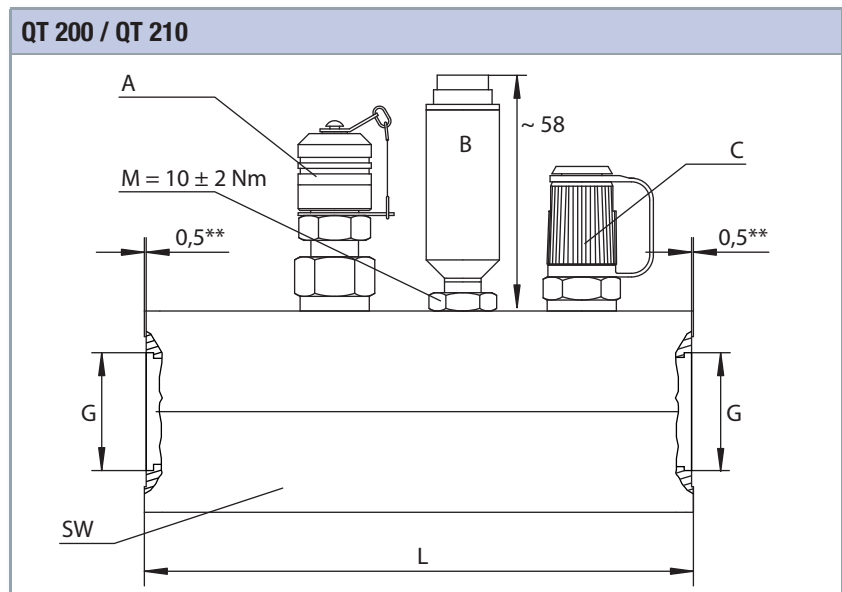

Measuring range	L	SW	G
l/min	mm		
1.0 ... 10.0	120	41	ISO 228-G¼
7.5 ... 100	130	46	ISO 228-G¾
15 ... 300	150	55	ISO 228-G1¼
25 ... 600	174	60	ISO 228-G1½

- A MINIMESS® p/T test point for pressure and temperature, series 1620
- B max. tightening torque $M = 10 \pm 2$ Nm
- C inductive sensor / amplifier
- D MINIMESS® test point, series 1620
- H height is appr. 58 mm (for QT 200) and appr. 108 mm (for QT 210)
- * of current value for QT 200 and factory calibrated viscosity;
for QT 210 additional ± 0.2 % of final value (error f/l-converter)
- ** depth of spot face



HySense QT 206*

CAN turbine volume flow sensor



A version for CAN bus has been adapted from our high-precision turbine volume flow sensors with inside thread connector according to DIN ISO 228 for water and watery media.

The turbines are equipped with floating bearings and factory calibrated for water at 1 cSt. Other calibration viscosities are available on request.

10

Qualities	
Measuring principle	volume flow
Viscosity range	1 ... 10 mm ² /s (cSt)
Medium temperature	max. +120 °C
Environmental temperature	-20 ... +85 °C
Storage temperature	-20 ... +85 °C
Output signal	CANopen
Supply voltage U _b	8.5 ... 30 VDC
Electrical measuring connector	5 pole device connector, M12 x 1
Protection type (EN 60529 / IEC 529)	IP 67 (screwed)
Tightening torque	10 Nm (± 2 Nm)
Calibration viscosity	2,5 mm ² /s (cSt)
Material turbine casing	high-grade steel, passivated (X12CrNiS18 8)
Material turbine wheel	1.4122 (for measuring range 1.0 ... 10 l/min) 1.0718 (for all other measuring ranges)
Material sealings	FKM
Material sensor casing	3.1645
Current consumption	max. 50 mA @ 24 VDC
Interface	CANopen (CIA-DS-301)
CAN standard	2.0A (opt. 2.0B)
Transmission rate	20 ... 1,000 kBit/s
Measured frequency (Hz)	bytes 0 ... 3
Measured volume flow (l/min)	bytes 4 ... 7
Resolution	three decimal places
Suitable measuring cable	CAN cable

Pin assignment	CANopen
	Pin 1 = CAN_SHLD
	Pin 2 = CAN_V+
	Pin 3 = CAN_GND
	Pin 4 = CAN_H
	Pin 5 = CAN_L

*: former product name RE6

Measuring range	Max. working pressure		Error limit	Weight	Order number
	l/min	bar			
1.0 ... 10.0	420	42	± 1.0 %	746	33C7-01-35.001
5.0 ... 100	420	42	± 0.5 %	1,990	33C7-77-35.001G
15 ... 300	420	42	± 0.5 %	3,590	33C7-78-35.001G
25 ... 600	350	35	± 0.5 %	4,043	33C7-79-35.001G

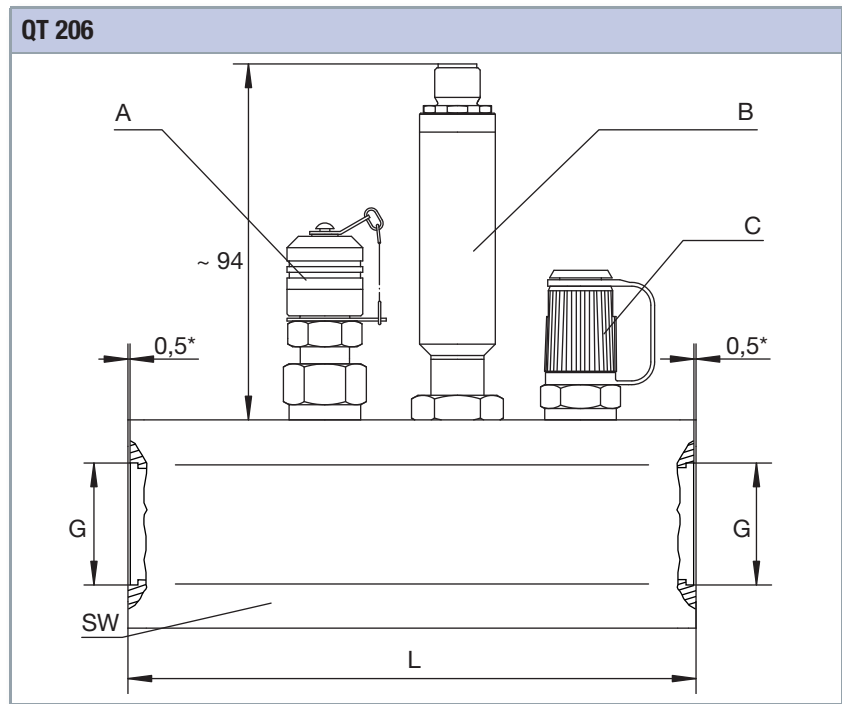

Measuring range	SW	L	G
l/min		mm	
1.0 ... 10.0	27	120	ISO 228-G¼
5.0 ... 100	46	130	ISO 228-G¾
15 ... 300	55	150	ISO 228-G1¼
25 ... 600	60	174	ISO 228-G1½

- A MINIMESS® p/T-test point for pressure and temperature, series 1620
- B inductive sensor / amplifier
- C MINIMESS® test point, series 1620
- * depth of spot face



HySense QT 218*

Turbine volume flow sensor with increased IP protection



High-precision turbine volume flow sensor with inside thread connector in accordance to DIN ISO 228 and increased IP protection for use with water and watery media, preferably.

The turbines are equipped with flow bearings and factory calibrated for water at 1 cSt. Other calibration viscosities are available on request.

10

Qualities	
Measuring principle	volume flow
Viscosity range	1 ... 10 mm ² /s (cSt)
Medium temperature	max. +120 °C
Environmental temperature	-20 ... +85 °C
Storage temperature	-20 ... +85 °C
Output signal	4 ... 20 mA
Supply voltage U _b	12 ... 24 VDC
Electrical measuring connector	device connector AMP 3 pole, acc. to DIN 72585
Protection type (EN 60529 / IEC 529)	IP 69
Tightening torque	10 Nm (± 2 Nm)
Calibration viscosity	2,5 mm ² /s (cSt)
Material turbine casing	high-grade steel, passivated X12CrNiS18 8
Material turbine wheel	1.4122 (for measuring range 1.0 ... 10 l/min) 1.0718 (for all other measuring ranges)
Material sealings	FKM
Material sensor casing	1.4571
Suitable measuring cable	customer-specific

Pin assignment	4 ... 20 mA
	Pin 1 = signal +
	Pin 2 = signal - / GND
	Pin 3 = + U _b

Measuring range	Max. working pressure		Error limit	Weight	Order number
	l/min	bar			
1.0 ... 10.0	420	42	± 2.5 %	736	33N7-01-35.001
7.5 ... 100	420	42	± 2.5 %	1,980	33N7-77-35.001G
15 ... 300	420	42	± 2.5 %	3,574	33N7-78-35.001G
25 ... 600	350	35	± 2.0 %	4,033	33N7-79-35.001G

*: former product name RE6

Dimensions

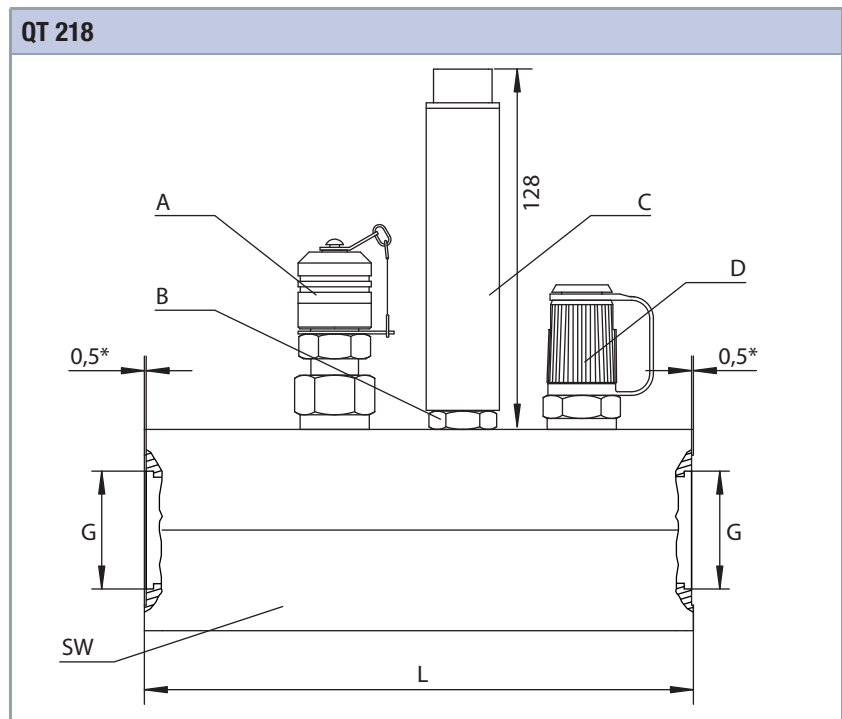

Measuring range	L	SW	G
l/min	mm		
1.0 ... 10.0	120	41	ISO 228-G $\frac{1}{4}$
7.5 ... 100	130	46	ISO 228-G $\frac{3}{4}$
15 ... 300	150	55	ISO 228-G1 $\frac{1}{4}$
25 ... 600	174	60	ISO 228-G1 $\frac{1}{2}$

- A MINIMESS® p/T test point for pressure and temperature, series 1620
- B max. tightening torque $M = 10 \pm 2$ Nm
- C inductive sensor, amplifier
- D MINIMESS® test point, series 1620
- * depth of spot face

delta-P curves

The delta-P curves shown here relate to the volume flow sensors of the HySense® QT 2xx range shown on the previous pages:

- QT 200
- QT 206
- QT 210
- QT 218

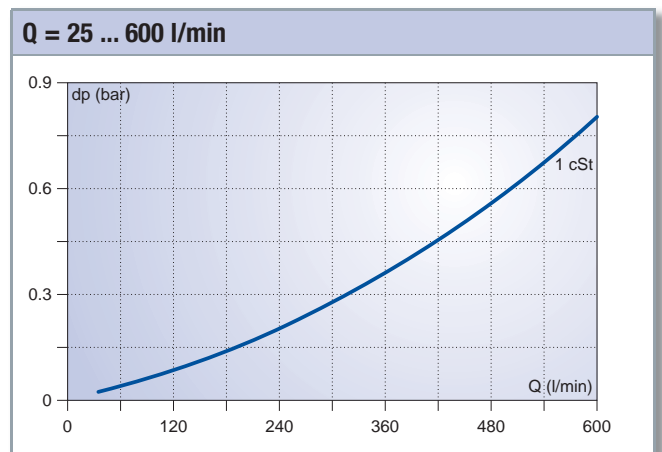
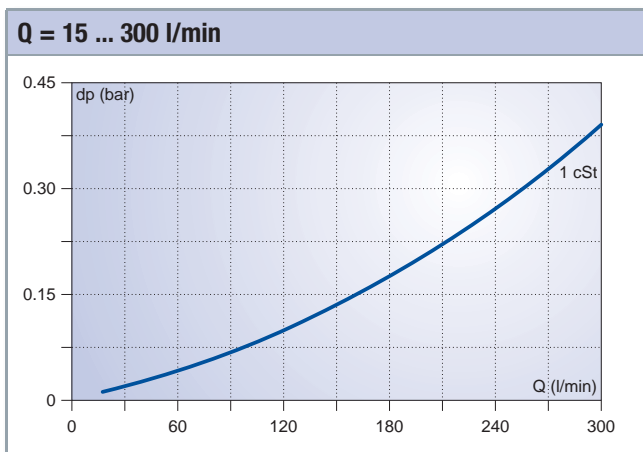
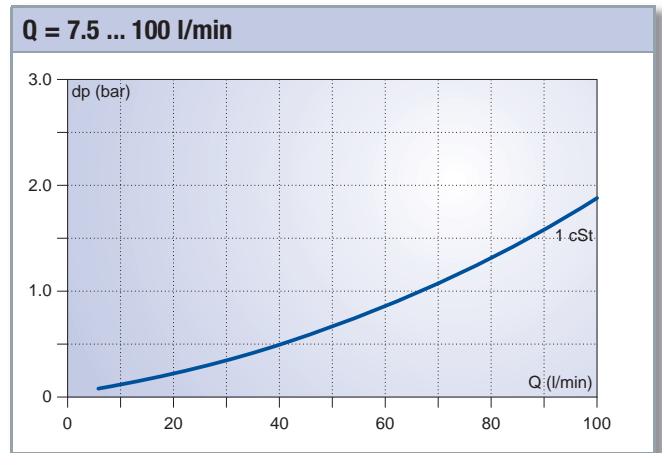
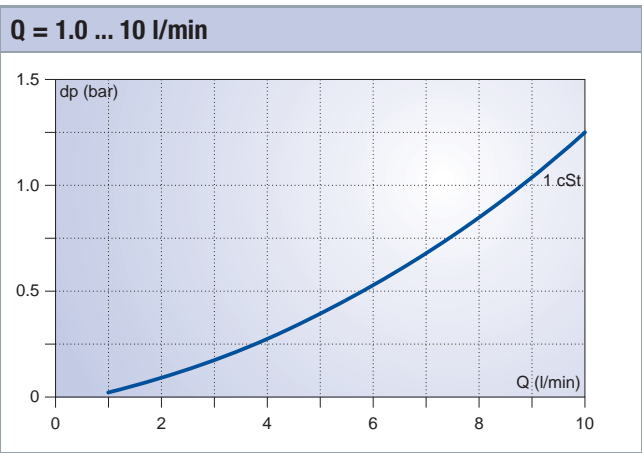

QT

HySense® QT 300



Turbine volume flow sensor

1000
l/min

10



NEW

The completely new HySense® QT 300 measures volume flow rates up to 1,000 l/min and is capable of a pressure load up to 420 bar.

Two MINIMESS® test points serially enable problem-free collection of further measurands (pressure, temperature) simultaneously.

Safe integration into existing pressure systems is possible with the 2" SAE flange connectors delivered with the turbines.

Qualities

Measuring principle	volume flow
Viscosity range	1 ... 100 mm ² /s (cSt)
Medium temperature	max. +120 °C
Environmental temperature	-20 ... +85 °C
Storage temperature	-20 ... +85 °C
Output signal	frequency (rectangular signal)
Supply voltage U _b	6.5 ... 30 VDC
Error limit	± 3.0 % of current value
Electrical measuring connector	5 pole device connector, M16 x 0.75
Protection type (EN 60529 / IEC 529)	IP 40
Tightening torque	10 Nm (± 2 Nm)
Calibration viscosity	30 mm ² /s (cSt)
Material turbine casing	high-grade steel X10CrNiS189 (1.4305)
Material turbine wheel	1.4104
Material sealings	FKM
Material sensor casing	3.1645
Suitable measuring cable	MK 01

Contained in delivery:

- 4 pc. SAE-flange halves 2", straight (420 bar)
- 1 pc. SAE-sealing (O ring) ID 56.74x3.53 90 shore A, NBR
- 8 pc. cylinder screws DIN 912 (ISO 4762) M20 x 70 – 8.8

Pin assignment

Pin assignment	Frequency (rectangular signal)
	Pin 1 = signal +
	Pin 2 = - U _b / signal - / GND
	Pin 3 = + U _b
	Pin 4 = free
	Pin 5 = free

Measuring range	Max. working pressure		Error limit	Weight	Order number
	l/min	bar			
45 ... 1,000	420	42	± 3.0 %	11,440*	31WD-88-35.030

*: with flanges and cylinder screws

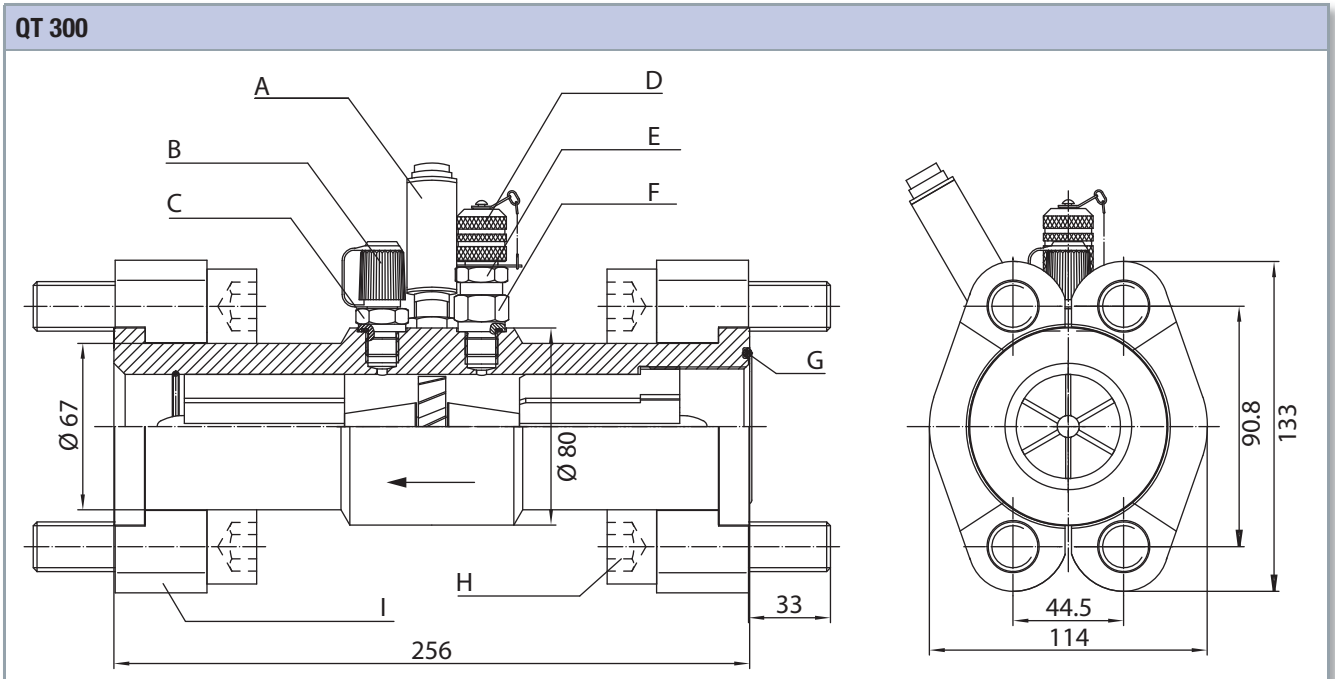

- A Inductive sensor with amplifier, screw-in thread M14 x 1
- B MINIMESS® test point, series 1620
- C max. tightening torque $M_{Amax} = 40 \text{ Nm}$
- D MINIMESS® p/T-test point for pressure and temperature, series 1620
- E max. tightening torque $M_{Amax} = 16 \text{ Nm}$
- F max. tightening torque $M_{Amax} = 40 \text{ Nm}$
- G SAE sealing (O ring) ID 56.74 x 3.53 90 shore A, NBR
- H 8 pc. hexagon cylinder screws, ISO 4762-M20 x 70 – 8.8
- I 4 pc. SAE flange halves 2", high-pressure version 42 MPa (6,000 PSI)

Q = 45 ... 1,000 l/min

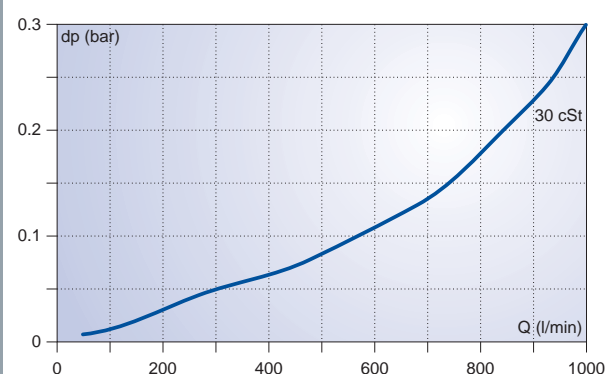

HySense QO 100

Oval wheel counter for minimal flow rates

The oval wheel counter QO 100 has been developed for the accurate measurement of minimal volume flow rates. They are robust and characterized by their simplicity and user-friendliness. Typical media are water and watery media, but they can also be used for oil, grease and petrol.



Similar illustration

Qualities	
Measuring principle	displacement
Viscosity range	1 ... 150 cSt
Medium temperature	-10 ... +70 °C
Environmental temperature	-10 ... +60 °C
Storage temperature	-10 ... +70 °C
Output signal	REED, NPN
Allowed working pressure	40 bar / 4 MPa
Error limit (calibrated)	< ± 0.5 % of current value
Repeatability	0.1 % of measured value
Electrical measuring connector	depends on output signal
Protection type (EN 60529 / IEC 529)	IP 67
Process connection	inside thread G 1/8" or 1/4"
Calibration viscosity	1 mm ² /s (cSt)
Materials	Aluminium, PPS
EMC test	DIN EN 60947-5-2
Sealings	FKM

Available in several versions:

- different output signals
- different materials
- different calibration viscosities
- on-site display



Q = 0.1 ... 1.0 l/min

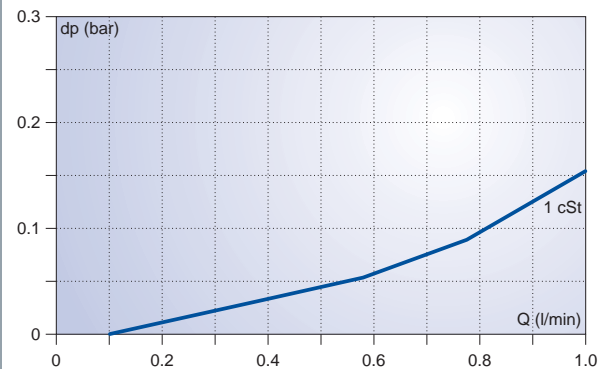

Measuring range	Output signal	Weight	Order number
l/min		g	
0.1 ... 1.0	REED	820	F130-11-11.11
	NPN		F140-11-11.11



HySense QO 200

Oval wheel counter for low volume flow rates



Similar illustration



The oval wheel counters QO 200 are built up modularly to make them suitable for a broad range of applications. They are very robust and user-friendly as a result of their simplicity.

Qualities	
Measuring principle	displacement
Viscosity range	1.5 ... 150 cSt
Medium temperature	-10 ... +80 °C
Environmental temperature	-10 ... +55 °C
Storage temperature	-10 ... +55 °C
Output signal	REED, NPN
Allowed working pressure	40 bar / 4 MPa
Supply voltage U_b	10 ... 30 VDC
Error limit (calibrated)	$< \pm 0.5\%$ of current value
Process connection	inside thread G 1/2"
Electrical measuring connector	depends on output signal
Protection type (EN 60529 / IEC 529)	IP 67
Calibration viscosity	1 mm ² /s (cSt)
Materials	Aluminium, PPS
Sealings	NBR

Available in several versions:

- different output signals
- different materials
- different calibration viscosities
- different measuring ranges
- on-site display



Q = 1 ... 10 l/min

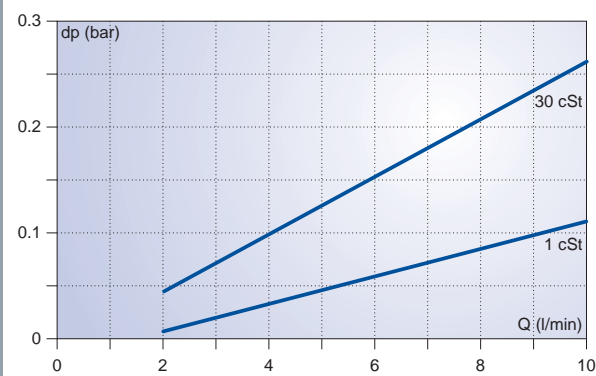

Messbereich	Ausgangssignal	Gewicht	Bestellnummer
l/min		g	
0.2 ... 2.0	REED	2,200	F230-16-13.31
	NPN		F240-16-13.31
0.5 ... 5.0	REED	2,400	F330-16-13.31
	NPN		F340-16-13.31
1.0 ... 10	REED	2,700	F430-16-13.31
	NPN		F440-16-13.31

HySense QO 300

High-precision oval wheel counter for low volume flow rates

The oval wheel counters QO 300 work with very high precision and can be used for many applications. They are suitable for oily media, as long as they do not corrode aluminium; e.g. for hydraulic and grease oils, and petrols in process and laboratory environments.



Similar illustration



Important note:

Please consider when applying the QO 300 that it may not be used for media that corrode Aluminium.

Qualities	
Measuring principle	displacement
Viscosity range	3 ... 2,300 cSt
Medium temperature	-10 ... +80 °C (up to +130 °C on request)
Environmental temperature	-20 ... +65 °C
Storage temperature	-20 ... +65 °C
Output signal	REED, NPN
Allowed working pressure	16 bar / 1.6 MPa
Supply voltage U_b	10 ... 30 VDC
Error limit (of current value)	$\pm 0.3\% \dots \pm 1.0\%$ ($\pm 0.05\%$ on request)
Process connection	inside thread G 3/4"
Electrical measuring connector	depends on output signal
Protection type (EN 60529 / IEC 529)	IP 50
Calibration viscosity	3 mm ² /s (cSt)
Materials	Aluminium
Sealings	compound 19457

Available in several versions:

- different output signals
- different materials
- different calibration viscosities
- on-site display



Q = 1 ... 10 l/min

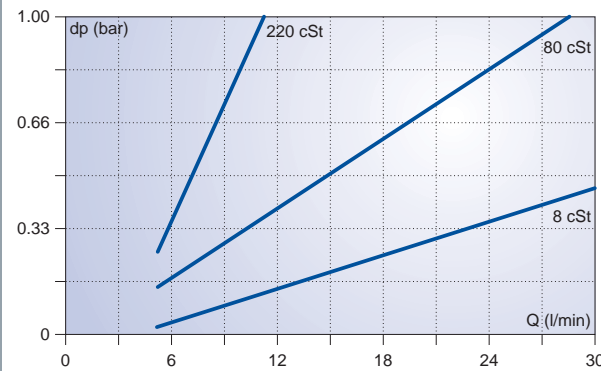

Measuring range	Output signal	Weight	Order number
l/min		g	
1 ... 30	REED	1,400	F770-57-35.64
	NPN		on request

Turbine volume flow sensors with load valve**Volume flow measuring under load**

Testing of pumps, e.g. the recording of a characteristic curve in dependency of the pressure is simplified significantly by using the HySense QL sensors, as a nonexistent load can be simulated.

Volume flow sensor (turbine), load valve and test points for pressure and temperature are combined in a single unit. The mechanical connection (inlet and outlet) are designed as inside thread 150 228-G 1¼".

The required pressure protection must be provided by the customer, e.g. by mounting a pressure limiting valve in front of the HySense QL, or with the upstream hydraulic system.

Application examples

- Hydraulic load simulations
- Hydraulic performance test and efficiency measurements
- Component tests
- Load setting of hydraulic components
- Pump tests

Special advantages of HySense QL

- measuring of pressure and temperature with separate sensors
- sensitive pressure adjustment
- all controls are easy to operate
- versions for 0 ... 300 and 0 ... 600 l/min available

Please ensure that the hydraulic system has an adequate pressure protection when using HySense QL load valves!



Turbine volume flow sensor with load valve



Qualities	
Measuring principle	volume flow
Viscosity range	1 ... 100 mm ² /s (cSt)
Medium temperature	max. +120 °C
Environmental temperature	-20 ... +85 °C (short-term up to +100 °C)
Storage temperature	-20 ... +85 °C
Output signal	frequency (rectangular signal) / 4 ... 20 mA
Supply voltage U _b	12 ... 24 VDC
Error limit	± 2.5 % of current value
Electrical measuring connector	5 pole device connector, M16 x 0.75
Protection type (EN 60529 / IEC 529)	IP 40
Tightening torque (sensor)	10 Nm (± 2 Nm)
Calibration viscosity	30 mm ² /s (cSt)
Material turbine casing	Aluminium (AlZnMgCu 1,5)
Material turbine wheel	1.0718
Material sealings	FKM
Material sensor casing	3.1645 (QL 100) / 1.4301 (QL 110)
Suitable measuring cable	MK 01

Pin assignment	QL 100 (frequency)	QL 110 (4 ... 20 mA)
	Pin 1 = signal +	Pin 1 = signal +
	Pin 2 = - U _b / signal - / GND	Pin 2 = signal - / GND
	Pin 3 = + U _b	Pin 3 = + U _b
	Pin 4 = free	Pin 4 = free
	Pin 5 = free	Pin 5 = free

Version	Measuring range	Max. working pressure		Weight	Order number
		bar	MPa		
	l/min			g	
QL 100	15 ... 300	350	35	4,324	31VB-71-35.030
QL 110	15 ... 300	350	35	4,461	31GB-71-35.030

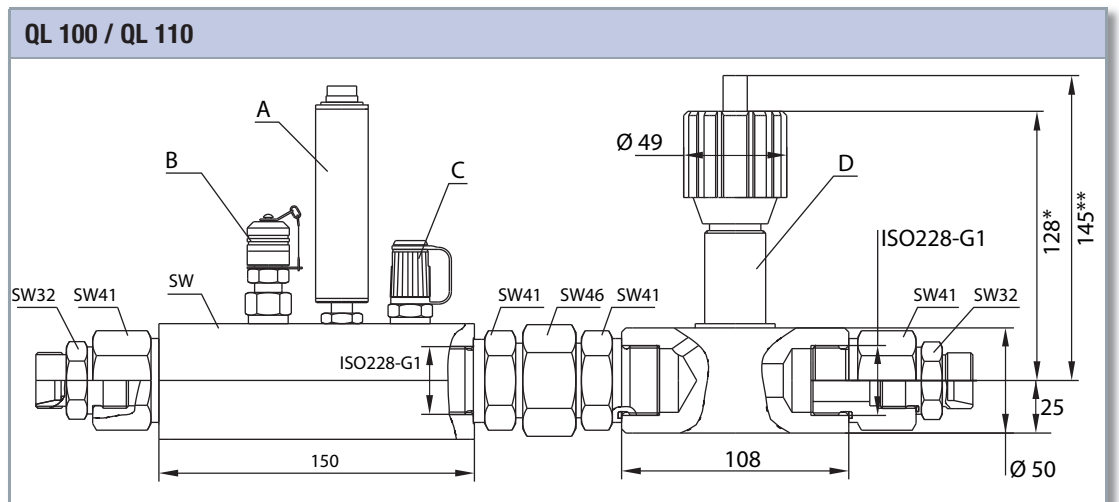

Decoding „L“ and „G“ see order data

A f/l-converter 4 ... 20 mA

B MINIMESS® p/T-test point for pressure and temperature, series 1620

C MINIMESS® test point, series 1620

D throttle valve NG 20

* closed

** opened

Q = 15 ... 300 l/min

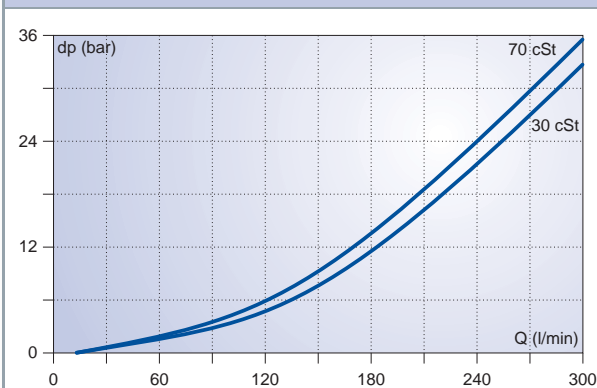



Turbine volume flow sensor with load valve



Qualities	
Measuring principle	volume flow
Viscosity range	1 ... 100 mm ² /s (cSt)
Medium temperature	max. +120 °C
Environmental temperature	-20 ... +85 °C (short-term up to +100 °C)
Storage temperature	-20 ... +85 °C
Output signal	frequency (rectangular signal)
Supply voltage U _b	6.5 ... 30 VDC
Error limit	± 2.5 % of current value
Electrical measuring connector	5 pole device connector, M16 x 0.75
Mechanical measuring connector	ISO228-G1¼
Protection type (EN 60529 / IEC 529)	IP 40
Tightening torque (sensor)	10 Nm (± 2 Nm)
Calibration viscosity	30 mm ² /s (cSt)
Material turbine casing	Aluminium (3.4365)
Material turbine wheel	1.0718
Material sealings	FKM
Material sensor casing	3.1645
Suitable measuring cable	MK 01

Pin assignment	Frequency (rectangular signal)
	Pin 1 = signal +
	Pin 2 = - U _b / signal - / GND
	Pin 3 = + U _b
	Pin 4 = free
	Pin 5 = free

Measuring range	Max. working pressure		Weight	Order number
	bar	MPa		
l/min	bar	MPa	g	
16 ... 600	420	42	6,516	31VB-72-35.030A2

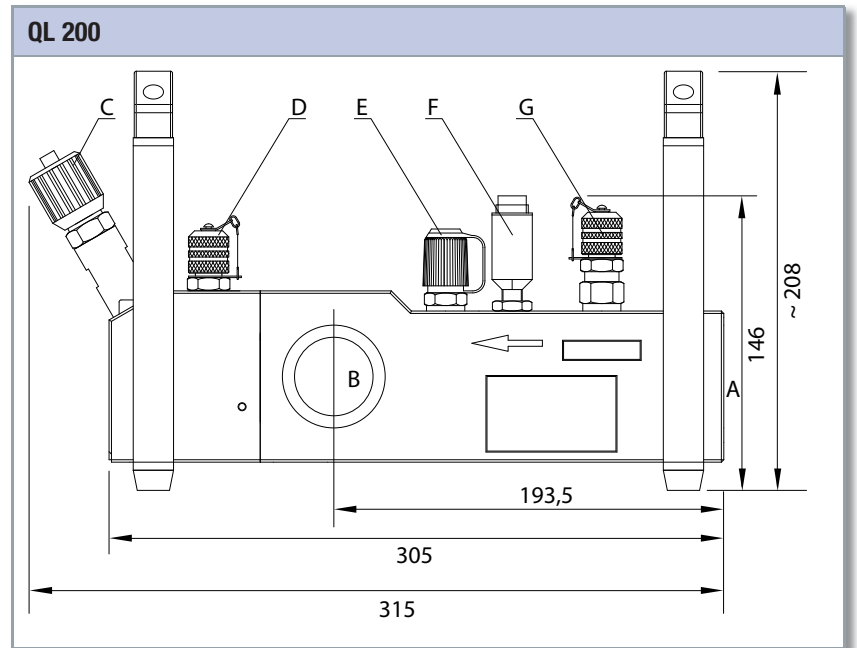

- A Inlet connector
- B Outlet connector
- C Throttle valve for continuous pressure adjustment
- D MINIMESS® test point for ventilation, series 1620
- E MINIMESS® test point, series 1620
- F Inductive sensor
- G MINIMESS® p/T-test point for pressure and temperature, series 1620

Q = 12 ... 600 l/min

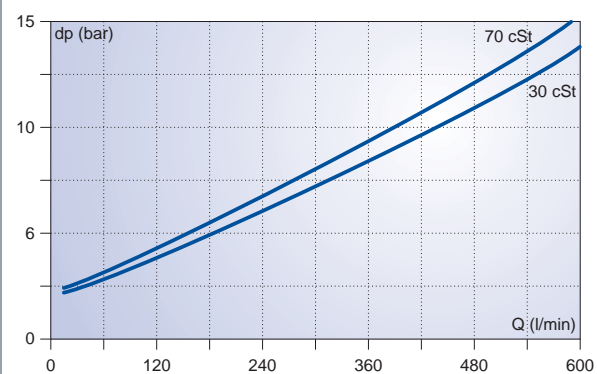

Temperature sensors

Temperature is an important measurand especially for exact determination of viscosity and density of the fluid, and therefore the reproducibility of measuring results. Hyrotechnik offers several models for the fast and reliable capture of the medium temperature:

- TE 110
- TE 118
- TP 180

Connector version

The second digit of the model name indicates the connector type:

0	6 pole device connector, M16 x 0.75
1	5 pole device connector, M16 x 0.75
2	5 pole device connector, M12 x 1
3	4 pole device connector, M12 x 1
4	4 pole device connector, EN 175301-803 type A, Pg9
5	4 pole device connector, EN 175301-803 type C, Pg7
8	other connector versions
9	open cable ends

HySense TE 110

Screw-in sensor for temperature measurement

This sensor is qualified by some specific characteristics. It can be installed in any orientation and achieves highly accurate values, as it is measuring in the medium directly. It can be installed and dismantled easily by screwing it into a 1620 series p/T-test point.



Qualities	
Screw series	1620
Measuring principle	Pt 100 (platinum measuring resistor acc. to DIN 43760, class B)
Measuring range	-50 ... +200 °C
Output signal	0 ... 20 mA / 4 ... 20 mA
Signal type	three wires (0 ... 20 mA) / two wires (4 ... 20 mA)
Supply voltage U_b	10 ... 30 VDC
Overvoltage protection	36 VDC
Error limit	< $\pm 1\%$ of final value
Temperature error	< $\pm 0.3\%$ / 10 °C
Pressure load capacity	max. 630 bar / 63 MPa
Environmental temperature	-20 ... +80 °C (related to electronics)
Storage temperature	-20 ... +85 °C
Electrical measuring connector	5 pole device connector, M16 x 0.75
Mechanical measuring connector	see drawing
Protection type (EN 60529 / IEC 529)	IP 67
Material	1.4104
Suitable measuring cable	MK 01

Pin assignment	0 ... 20 mA	4 ... 20 mA
	Pin 1 = signal +	Pin 1 = - U_b / signal -
	Pin 2 = signal - / GND	Pin 2 = free
	Pin 3 = + U_b	Pin 3 = + U_b / signal +
	Pin 4 = free	Pin 4 = free
	Pin 5 = free	Pin 5 = free

Output signal	Weight	Order number
	g	
0 ... 20 mA	230	3973-04-01.00S
4 ... 20 mA	230	3969-04-01.00S
4 ... 20 mA	200	3354-10-02.00S

Dimensions see page 57

HySense TE 118

Screw-in temperature sensor

This sensor is qualified by some specific characteristics. It can be installed in any orientation and achieves highly accurate values, as it is measuring within the medium. It has IP 69 and can be installed and dismantled easily by screwing it into a 1620 series p/T-test point.



Qualities	
Screw series	1620
Measuring principle	Pt 100 (platinum measuring resistor in acc. to DIN 43760, class B)
Measuring range	-50 ... +200 °C
Output signal	4 ... 20 mA
Signal type	two wires
Supply voltage U_b	10 ... 30 VDC
Overvoltage protection	36 VDC
Error limit	< $\pm 1\%$ of final value
Temperature error	< $\pm 0.3\%$ / 10 °C
Pressure load capacity	max. 630 bar / 63 MPa
Environmental temperature	-20 ... +80 °C (related to electronics)
Storage temperature	-20 ... +85 °C
Electrical measuring connector	device connector AMP 3 pole, acc. to DIN 72585
Mechanical measuring connector	see drawing
Protection type (EN 60529 / IEC 529)	IP 69
Material	1.4104
Suitable measuring cable	customer-specific

Pin assignment	4 ... 20 mA
	Pin 1 = - U_b / signal -
	Pin 2 = free
	Pin 3 = + U_b / signal +

Output signal	Weight	Order number
	g	
4 ... 20 mA	200	3969-04-05.00

Dimensions see page 57



HySense TE 110 / TE 118

Dimensions

TE 110

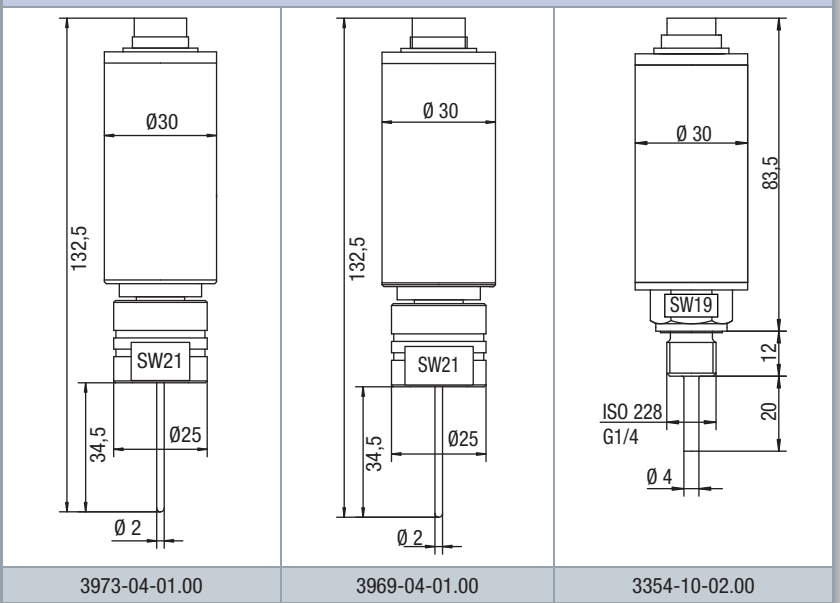

TE 118

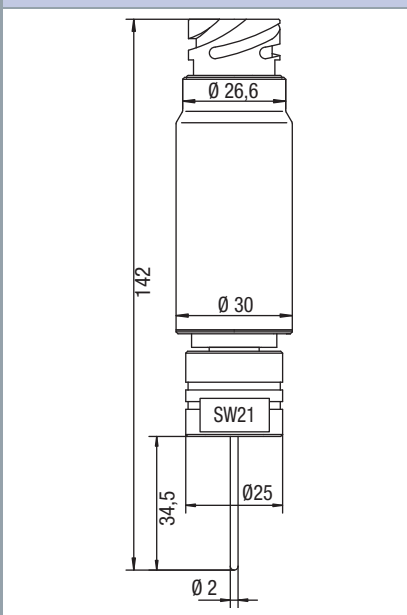

HySense TP 180

Dual sensor for temperature and pressure

This sensor is able to measure pressure and temperature simultaneously at a single test point. It can be installed in any orientation and achieves highly accurate values, as it is measuring within the medium. It can be installed and dismantled easily by screwing it into a 1620 series p/T-test point.



TP

Qualities	
Screw series	1620
Output signal	4 ... 20 mA
Signal type	two wires
Supply voltage U_b	10 ... 30 VDC
Overvoltage protection	36 VDC
Environmental temperature	-20 ... +80 °C
Storage temperature	-20 ... +85 °C
Electrical measuring connector	8 pin device connector
Mechanical measuring connector	see drawing
Load resistor	0 ... 1 kOhm
Protection type (EN 60529 / IEC 529)	IP 40
Materials	1.4435, 1.4571
Material sealings	NBR
Weight	est. 255 g
Qualities of the temperature sensor	
Measuring principle	Pt 100 (platinum measuring resistor acc. to DIN 43760, class B)
Measuring range	-50 ... +200 °C
Error limit	< ± 1 % of final value
Temperature error	< ± 0.3 % / 10 °C
Qualities of the pressure sensor	
Measuring principle	piezoresistive (poly-cristalline silicon thin film structure on a high-grade steel membrane)
Measuring range	0 ... 60 / 600 bar
Over load range	1.5-fold nominal pressure
Non-linearity (incl. hysteresis)	± 0.5 % of final value
Reproducibility	< ± 0.15 % of final value
Compensated temperature range	-10 ... +80 °C
Temperature coefficient	
... zero point	< 0.01 % / K of final value
... measuring span	< 0.01 % / K of final value
Membrane resonance frequency	> 30 kHz
Number of load cycles	> 10 x 10 ⁶

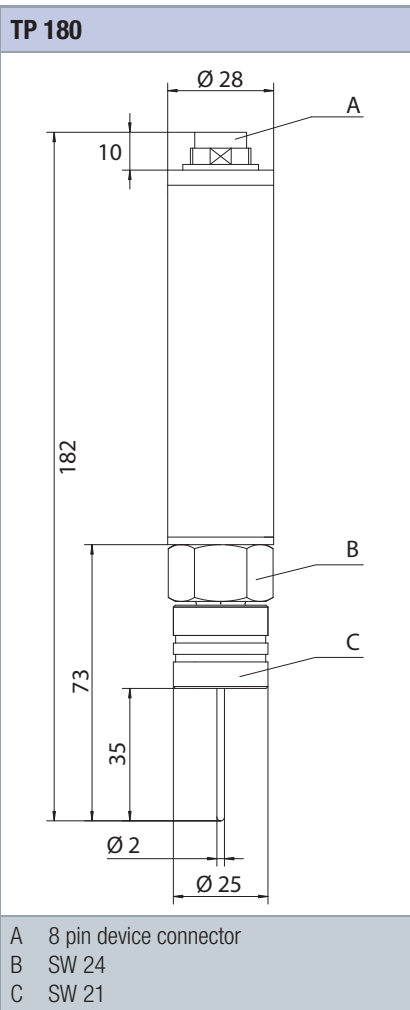

Pin assignment	4 ... 20 mA
	Pin 1 = + Ub / signal + (pressure)
	Pin 2 = - Ub / signal - (pressure)
	Pin 3 = free
	Pin 4 = + Ub / signal + (temperature)
	Pin 5 = - Ub / signal - (temperature)
	Pin 6 = free
	Pin 7 = free
	Pin 8 = shield

Measuring range pressure		Measuring range temperature	Order data
bar	MPa	°C	
0 ... 60	0 ... 6	-50 ... +200	3763-04-34.00
0 ... 600	0 ... 60	-50 ... +200	3763-03-34.00

HySense

Sensors for other measurands

With our HySense sensors, Hydrotechnik covers all important physical measurands of importance for diagnosis and condition monitoring of fluid-technical systems. On the following pages you can find precise and reliable sensors for

- rotational speed
- position
- force
- torque
- vibration



Connector version

The second digit of the model name indicates the connector type:

- | | |
|---|--|
| 0 | 6 pole device connector, M16 x 0.75 |
| 1 | 5 pole device connector, M16 x 0.75 |
| 2 | 5 pole device connector, M12 x 1 |
| 3 | 4 pole device connector, M12 x 1 |
| 4 | 4 pole device connector, EN 175301-803 type A, Pg9 |
| 5 | 4 pole device connector, EN 175301-803 type C, Pg7 |
| 8 | other connector versions |
| 9 | open cable ends |

Rotational speed sensor with reflection tag detection



Rotational speed measurement for many applications

The rotational speed sensor RS 110 uses pulsating red light (LED) reflected by a special tag at the rotating target. By using a polarisation filter, only the reflected light impulses are evaluated, disturbing reflections (e.g. unevenness of the surface, bright metal parts, keyways or high-contrast areas) are not detected. This achieves a reliable rotational speed measurement from distances between 0 and 500 mm. 25 reflection tags are included. Enter the number of used reflection tags as calibration value into the measuring instrument.

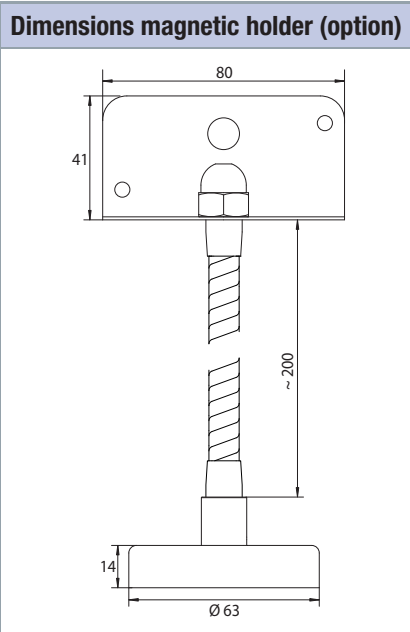
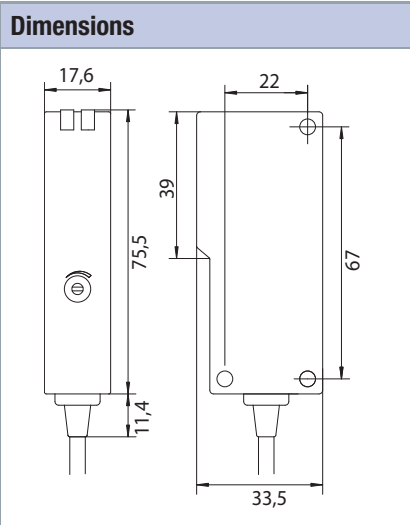

Applications

- Recording the hydraulic efficiency of pumps
- Rotational speed measurement of fans of hydraulic cooling devices

Qualities	
Measuring principle	auto-collimation
Light source	power LED with visible red light
Supply voltage U_b	10 ... 30 VDC
Ripple	< 5 Vss
Current consumption	< 30 mA
Output current max.	< 100 mA
Response time	500 μ s
Switching sequence	1,000 Hz
Range	0 ... 500 mm
Protection type	IP 67
Signal repetition frequency	max. 500 Hz
Output signal	frequency (rectangular signal) / 4 ... 20 mA
Electrical measuring connector	5 pole device connector, M16 x 0.75
Environmental temperature	-40 ... +60 °C
Storage temperature	-40 ... +75 °C
Weight	141 g

Pin assignment	RS 110 (frequency)	RS 110 (4 ... 20 mA)
	Pin 1 = signal +	Pin 1 = signal +
	Pin 2 = - U_b / GND	Pin 2 = signal - / GND
	Pin 3 = + U_b	Pin 3 = + U_b
	Pin 4 = free	Pin 4 = free
	Pin 5 = free	Pin 5 = free

Measuring range	Weight	Order number
	g	
Frequency	140	3130-02-01.00
4 ... 20 mA	320	3130-06-01.00



Inductive rotational speed sensor



Rotational speed measurement for special applications

The rotational speed sensor RS 210 works inductively and is able to detect the cogs of a cogwheel. After entering the number of cogs into the measuring instrument, a reliable rotational speed detection is assured. The sensor head must be mounted between 1.5 and 2 mm away from the cog wheel.

Dimensions

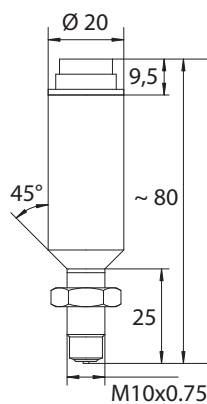

Qualities

Measuring principle	inductive with integrated amplifier switch
Measuring range	up to 5,000 divided by the number of cogs of the measured cog wheel
Output signal	frequency (rectangular signal)
Electrical measuring connector	5 pole device connector, M16 x 0.75
Mechanical connection thread	M 10 x 0.75
Material casing	Aluminium, anodized 20 µm, RAL 5015
Supply voltage U_b	6.5 ... 30 VDC
Current consumption	12 ... 15 mA
Overvoltage protection	36 VDC
Response time	0.1 ms
Frequency range	12.5 ... 5,000 Hz
Isolation resistor	1 MOhm
Total resistance	$R_g = U_b / 0.015 + I_L$
Load resistance	4 ... 20 kOhm
Environmental temperature	-20 ... +85 °C
Storage temperature	-20 ... +85 °C
EMV test	EN 50081-2, EN 50082-2
Mounting orientation	arbitrary
Weight	50 g

Pin assignment

Pin assignment	Frequency
	Pin 1 = signal +
	Pin 2 = - U_b / signal - / GND
	Pin 3 = + U_b
	Pin 4 = free
	Pin 5 = free

Output signal	Order number
Frequency	3107-00-09.00

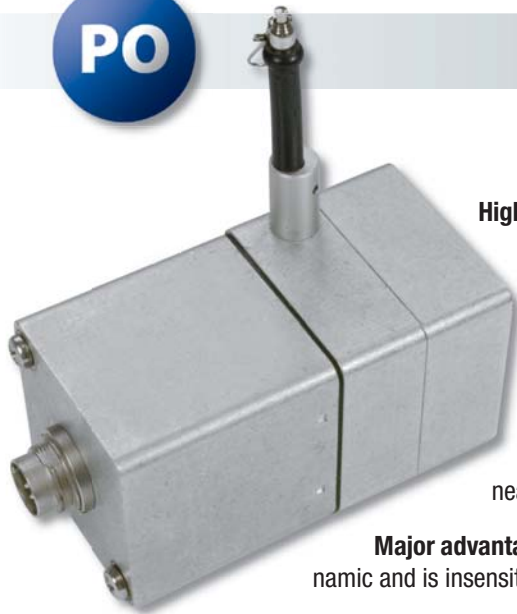

HySense PO 180

Position sensor with measuring wire

Highly accurate position measurement

The HySense PO 180 works on the measuring wire principle. It can be easily mounted and does not need linear guiding. It is suitable for use at load cranes, hydraulic presses and other installations where distances need to be measured or changes of position detected. All mechanical and electronic components are protected by a solid casing.

The measuring wire principle – a specially manufactured and calibrated wire is tightly wound around a high-precision drum that is driven against the pulled direction by a spring motor. Through the detection of the winding process the sensor converts the linear movement into an electrical signal.

Major advantages – The sensor is compact, has a very high resolution and accuracy. It has a high dynamic and is insensitive to environmental influences.

Please consider when using the PO 180: The exit angle of the wire from casing must be 90°, or there may be friction between the measuring wire and the casing, causing wear and tear. The top of the sensor should be protected against dirt and splash water and the measuring wire should not be positioned next to a machine or device part. The wire should never be loosened suddenly to avoid retraction into the casing.

Qualities	
Measuring principle	measuring wire
Output signal	4 ... 20 mA
Protection type (EN 60529 / IEC 529)	IP 65 (only with serial cable box)
Material casing / measuring wire	aluminium and high-grade steel / high-grade steel
Signal type	two wires
Supply voltage U_b	12 ... 27 VDC
Current consumption	max. 35 mA
Temperature coefficient	± 0.01 % / K
Nonlinearity	$< \pm 0.1$ % of the measuring range
Output noise	50 mVeff
Resolution	quasi infinite
Environmental temperature	-20 ... +85 °C
Storage temperature	-20 ... +85 °C
EMV test	IEC 1000-4-2, -4, -5
Vibrational stability	on request
Shock stability	on request

Pin assignment	4 ... 20 mA
	Pin 1 = + U_b / signal +
	Pin 2 = - U_b / signal -
	Pin 3 - 8 = free

Measuring range	Extraction force (max.)	Retraction force (max.)	Measure A	Weight	Order number
mm	N	N	mm	g	
0 ... 100	4.7	3.0	8.0	800	3183-13-03.37
0 ... 375	7.4	3.9	12.5	800	3183-13-05.37
0 ... 1,000	5.3	2.9	8.0	800	3183-13-02.37
0 ... 3,000	6.2	3.0	10.0	1,550	3183-12-02.37

PO 180 • measuring range 0 ... 3,000 mm

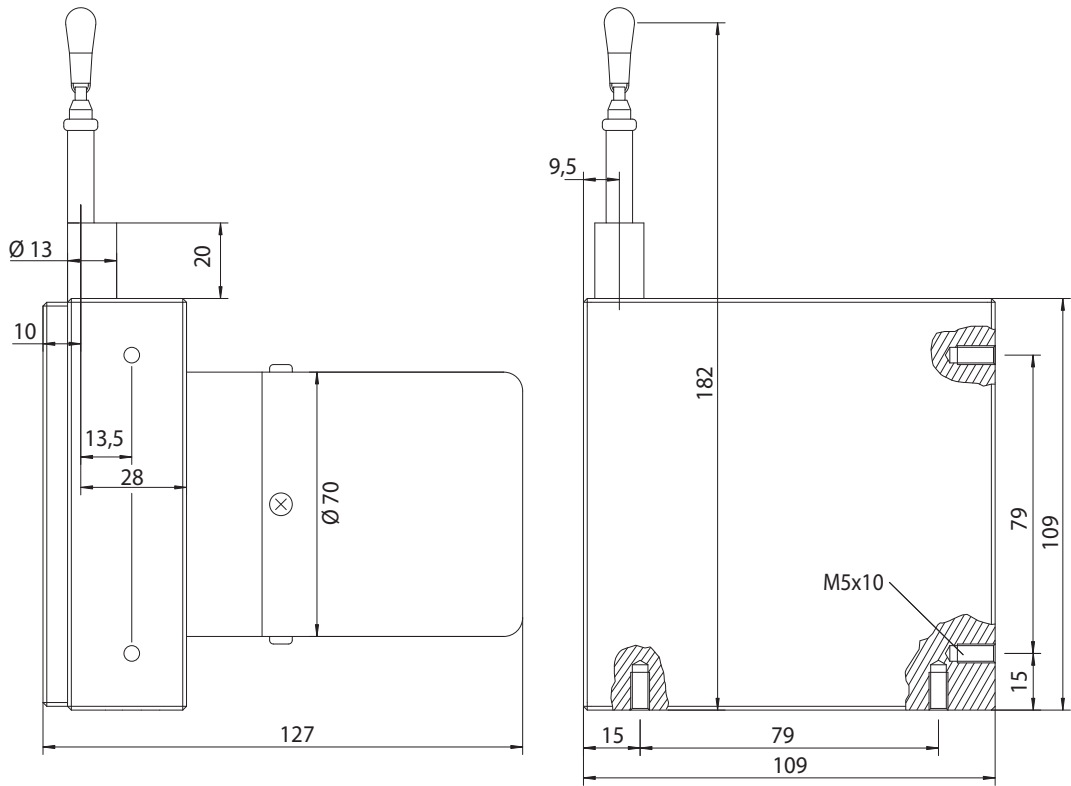

PO 180 • other measuring ranges

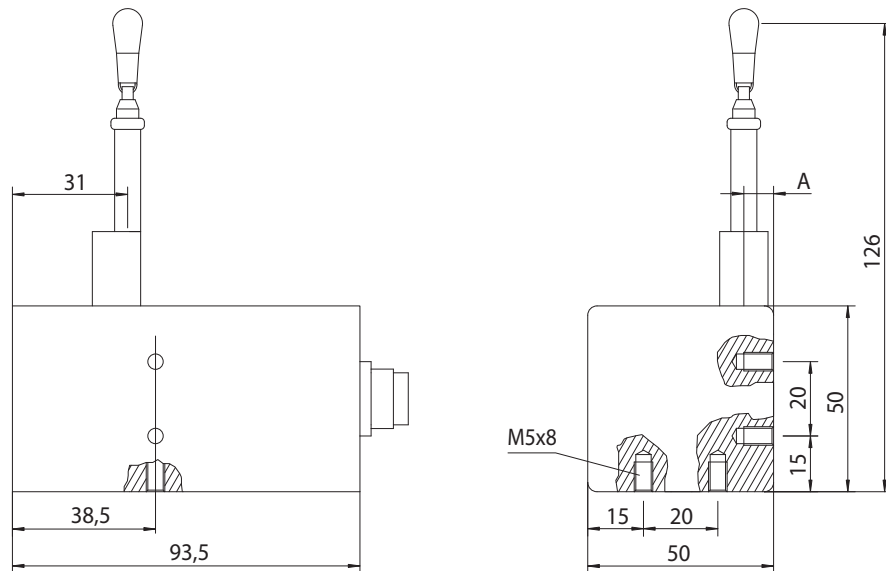



Force sensor according to the deflecting beam principle

The deflecting beam principle (shear force sensor)

Since a force and the deflection of a beam is proportional, this sensor is able to determine a force by measuring its elongation or change in length.

Due to its compact design, these traction-pressure force sensors can be used in the laboratory, as well as in industrial environments. Made with corrosion-proof steel, the sensors have a standardized nominal characteristic value. They can be mounted easily allowing simple integration into existing structures.

Measuring / collection of

- moulding and insertion forces
- spring forces
- cutting forces
- force and force control during assembly
- pressing forces in drilling machines

Qualities

Measuring principle	flexural beam
Output signal	4 ... 20 mA
Electrical measuring connector	5 pole device connector, M16 x 0.75
Protection type (EN 60529 / IEC 529)	IP 65
Material casing	steel
Signal type	three wires
Supply voltage U_b	10 ... 24 VDC
Current consumption	max. 40 mA
Error limit	< 0.5 % of final value
Temperature error NP	< ± 0.04 % of final value / K
Temperature error receiver	< ± 0.04 % of measuring range / K
Non-linearity	< ± 0.15 % of final value
Hysteresis	max. 0.1 % of final value
Calibration in	N
Calibration tolerance	< 0.25 % of final value
Environmental temperature	-15 ... +85 °C
Storage temperature	-15 ... +85 °C

Pin assignment

4 ... 20 mA

	Pin 1 = signal +
	Pin 2 = - U_b / signal -
	Pin 3 = + U_b
	Pin 4 = free
	Pin 5 = shield

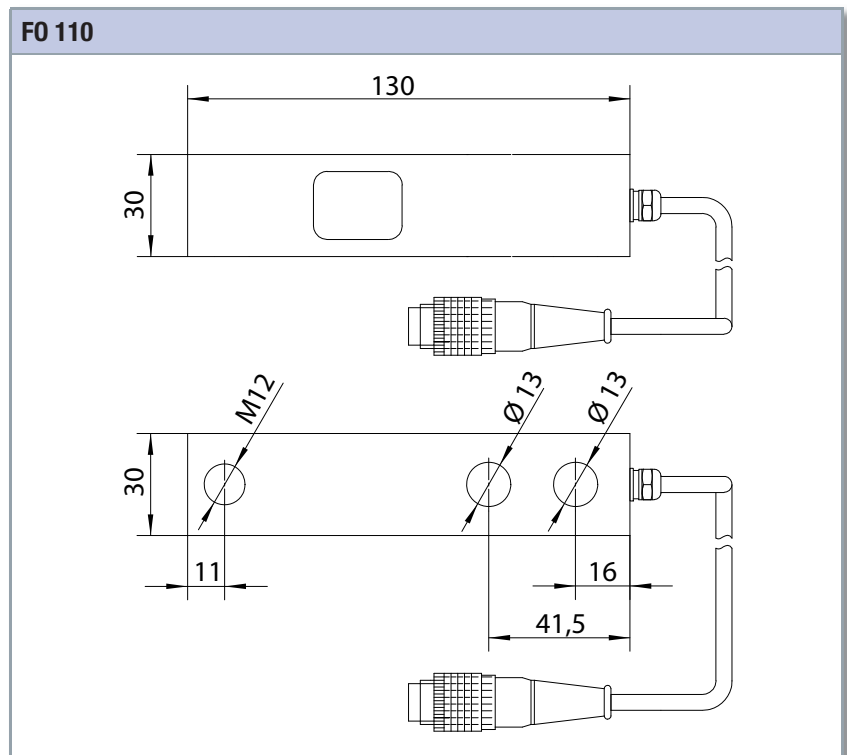

Measuring range	Overload capability	Breaking load	Material	Weight	Order number
kN	of nominal value	of nominal value		g	
0 ... 1.0	100 %	600 %	aluminium	~ 350	3183-4G-01.37
0 ... 1.5	50 %	400 %			3183-4G-02.37
0 ... 2.0	50 %	400 %			3183-4G-03.37
0 ... 5.0	100 %	600 %	steel	~ 750	3183-4G-04.37
0 ... 10.0	50 %	400 %			3183-4G-05.37
0 ... 20.0	50 %	400 %			3183-4G-06.37



Traction force sensor

The force sensor works to the principle of center-line force measurement. You can record traction forces at lifts, cranes and housings, or twistings of masts, towers or platforms.

The force sensor is a threaded rod. This allows easy and universal fastening. The application chamber for the resistance strain gauge is protected from mechanical and chemical damage by an aluminium tube, cast with a highly elastic compound. Full bridges of resistance strain gauges measure the elongation and lateral expansion caused by traction forces.



Qualities	
Measuring principle	center-line force measurement
Output signal	4 ... 20 mA
Electrical measuring connector	5 pole device connector, M16 x 0.75
Protection type (EN 60529 / IEC 529)	IP 65
Material casing	steel
Signal type	three wires
Supply voltage U_b	10 ... 24 VDC
Current consumption	max. 40 mA
Error limit	< 0.5 % of final value
Temperature error NP	< ± 0.04 % of final value / K
Temperature error receiver	< ± 0.04 % of measuring range / K
Non-linearity	< ± 0.25 % of final value
Hysteresis	< ± 0.15 % of final value
Calibration in	N
Calibration tolerance	< 0.5 % of final value
Environmental temperature	-15 ... +85 °C
Storage temperature	-15 ... +85 °C

Pin assignment	4 ... 20 mA
	Pin 1 = signal +
	Pin 2 = - U_b / signal -
	Pin 3 = + U_b
	Pin 4 = free
	Pin 5 = shield

Dimensions

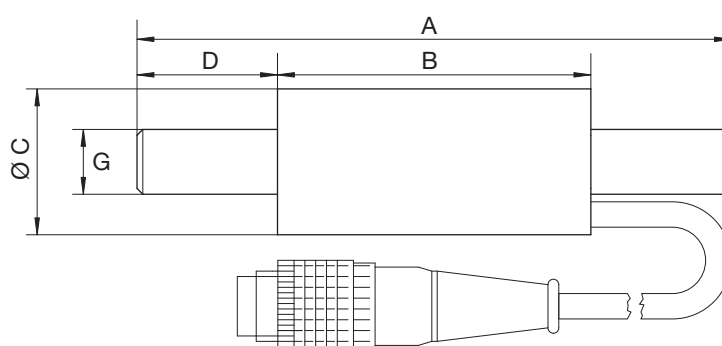

Measuring range	A	B	Ø C	D	G	Weight
kN	mm	mm	mm	mm		g
5	110	58	27	26	M12	170
10						170
20						180
50	100	40	40	30	M16 x 1.5	310
100	100	40	50	30	M24 x 2	500
150	130	60	50	35	M30 x 2	1,000
250	140	56	60	40	M36 x 2	1,380

Measuring range	Overload capability	Break load	Order number
kN	of nominal value	of nominal value	
0 ... 5	100 %	500 %	3183-41-01.37
0 ... 10	50 %	500 %	3183-41-02.37
0 ... 20	50 %	400 %	3183-41-03.37
0 ... 50	50 %	400 %	3183-41-04.37
0 ... 100	50 %	400 %	3183-41-05.37
0 ... 150	50 %	400 %	3183-41-07.37
0 ... 250	50 %	400 %	3183-41-06.37



Force sensors according to pressure force principle

Very small pressure force sensor for measuring ranges up to 100 kN that can be used to check moulding force (for example). It is manufactured with corrosion-free high-grade steel and protected in accordance to IP 65. It can be equipped with an overload protection on request.



Qualities	
Measuring principle	pressure force
Output signal	4 ... 20 mA
Electrical measuring connector	5 pole device connector, M16 x 0.75
Protection type (EN 60529 / IEC 529)	IP 65
Material casing	steel
Signal type	three wires
Supply voltage U_b	10 ... 30 VDC
Current consumption	< 50 mA
Error limit (23 °C)	< 0.5 % of final value
Working load	130 % of final value
Limit load	150 % of final value
Breaking load	300 % of final value
Max. dynamic load	70 % (acc. to DIN 50100)
Nominal measurement range	0.1 mm
Temperature coefficient	0.2 % / 10 K
Calibration in	N
Calibration tolerance	< 0.5 % of final value
Environmental temperature	0 ... +60 °C (Sensor -30 ... +80 °C)
Storage temperature	0 ... +60 °C
EMC test	IEC 801-2/4/5, EN 55011, EN 55022

Pin assignment	4 ... 20 mA
	Pin 1 = signal +
	Pin 2 = - Ub / signal -
	Pin 3 = + Ub
	Pin 4 = free
	Pin 5 = shield

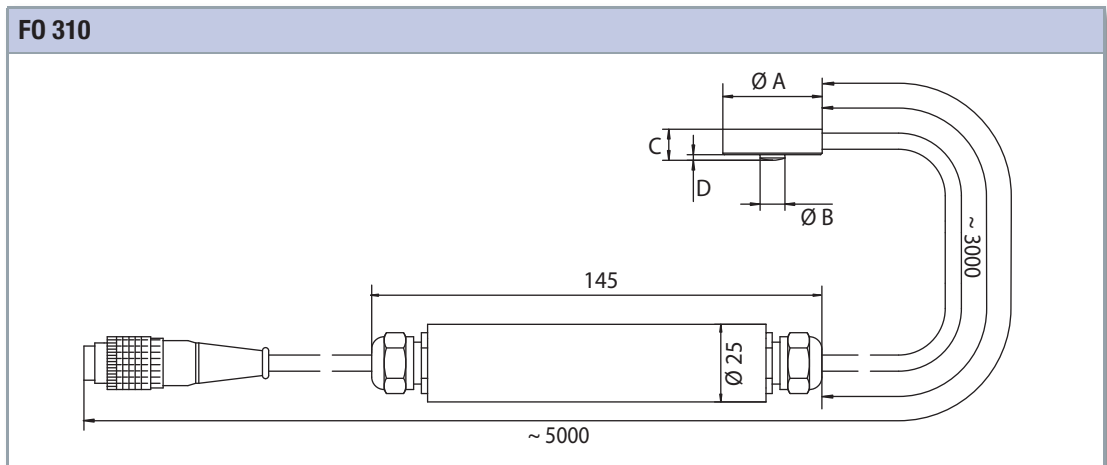

Measuring range	Ø A	Ø B	C	D	Weight	Order number
kN	mm	mm	mm	mm	g	
0 ... 1	32	8	10	1.8	~ 380	3183-42-01.37
0 ... 5	32	8	10	1.8	~ 380	3183-42-04.37
0 ... 10	32	8	10	1.8	~ 380	3183-42-08.37
0 ... 20	39	11	16	2.0	~ 450	3183-42-07.37
0 ... 50	52	15	25	3.0	~ 750	3183-42-06.37
0 ... 100	79	20	39	5.0	~ 1,500	3183-42-05.37



Rotating torque sensors with friction ring



Highly accurate torque sensor, equipped with a cylindric shaft with feather keys on both ends. It is available for several measurement ranges and is designed for continuous rotational speed of 1,500 to 2,000 rpm.

Qualities	
Measuring principle	rotating sensor with friction ring
Output signal	4 ... 20 mA
Nominal characteristic value	2 mV/V
Electrical measuring connector	5 pole device connector, M16 x 0.75
Mechanical measuring connector	cylindric shaft with feather keys
Protection type (EN 60529 / IEC 529)	IP 50
Signal type	three wires
Supply voltage U_b	8 ... 24 VDC
Current consumption	< 50 mA
Error limit	0.1 % of final value
Working torque	120 % of final value
Limit torque	130 % of final value
Breaking torque	250 % of final value
Factor range DIN 50100	70 % (peak – peak)
Maximal rotational speed	2,000 U/min
Twisting angle	0.5 ° at nominal torque
Reproducibility	± 0.05 %
Lifetime of brushes	5 x 10 ⁸ rotations
Nominal value tolerance	± 0.1 %
Environmental temperature	-10 ... + 60 °C
Storage temperature	-10 ... + 60 °C
EMC test	IEC 801-2/4/5, EN 55011, EN 55022

Pin assignment	4 ... 20 mA
	Pin 1 = signal +
	Pin 2 = - U_b / signal -
	Pin 3 = + U_b
	Pin 4 = free
	Pin 5 = shield

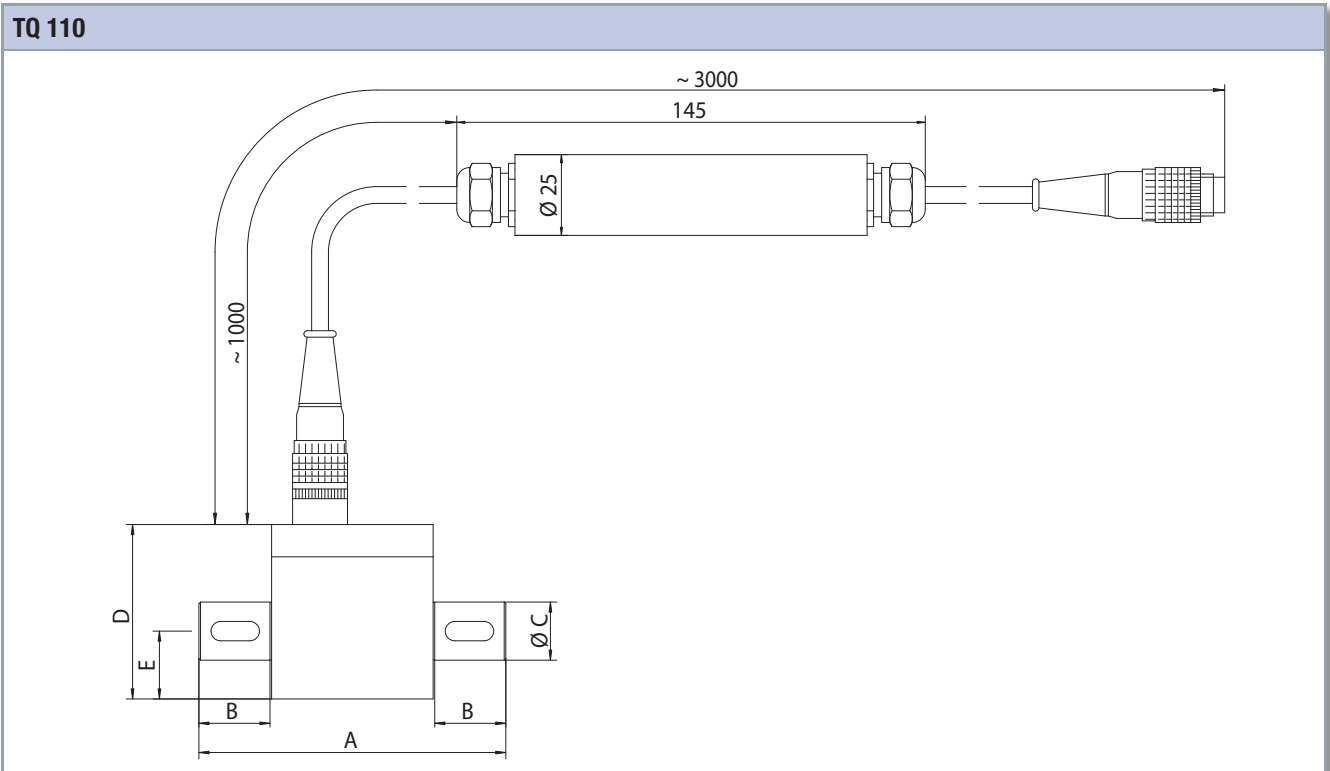

Measuring range	Max. cont. rot. speed	Spring constant	Max. radial load	Inertia*	A	B	C	D	E	Weight	Order number
Nm	min ⁻¹	Nm/rad	N	kg m ²	mm	mm	mm	mm	mm	g	
0 ... 50	1,500	4.82 x 10 ³	28	1.17 x 10 ⁻⁵	90	20	15	54	21	380	3183-21-0A.37
0 ... 63		9.85 x 10 ³	65	1.25 x 10 ⁻⁶						420	3183-21-06.37
0 ... 160	1,000	2.80 x 10 ⁴	80	9.15 x 10 ⁻⁵	95	22	18	54	21	900	3183-21-07.37
0 ... 500		6.33 x 10 ⁴	200	9.42 x 10 ⁻⁵							140

* inertia J in [kg m²] on the motor side



Vibration sensor



The vibration sensor comprises a capacitive acceleration sensor for data collection with short response time under serious environmental conditions. It is mounted on a magnetic foot that can be used to attach the sensor to any metallic surfaces. It reports vibrations by frequency and therefore can be connected to all Hydrotechnik measuring instruments.

Calibration values

Enter calibration value „1“ when used with MultiSystem 5060 and „1,000“ when used with MultiHandy 3010.

Qualities	
Measuring principle	capacitive acceleration sensor
Output signal	frequency (rectangular signal)
Signal height	$U_0 - 2V$
Frequency range	1 ... 100 Hz
Electrical measuring connector	5 pole device connector, M16 x 0.75
Mechanical connection	magnetic foot
Protection type (EN 60529 / IEC 529)	IP 66 (sensor element)
Material casing	plastic, resistant against petrol, oil, salt and certain chemicals (listing on request)
Signal type	three wires
Supply voltage U_b	8.5 ... 30 VDC
Current consumption	< 15 mA
Error limit	< $\pm 2\%$
Resolution	< 1 mg
Non-linearity	< $\pm 2\%$ of final value
Hysteresis	cannot be measured
Environmental temperature	-20 ... +85 °C
Storage temperature	-20 ... +85 °C
EMC test	on request
Shock stability	> 1,000 g

Pin assignment	Frequency
	Pin 1 = signal +
	Pin 2 = - U_b / signal - GND
	Pin 3 = + U_b
	Pin 4 = free
	Pin 5 = free

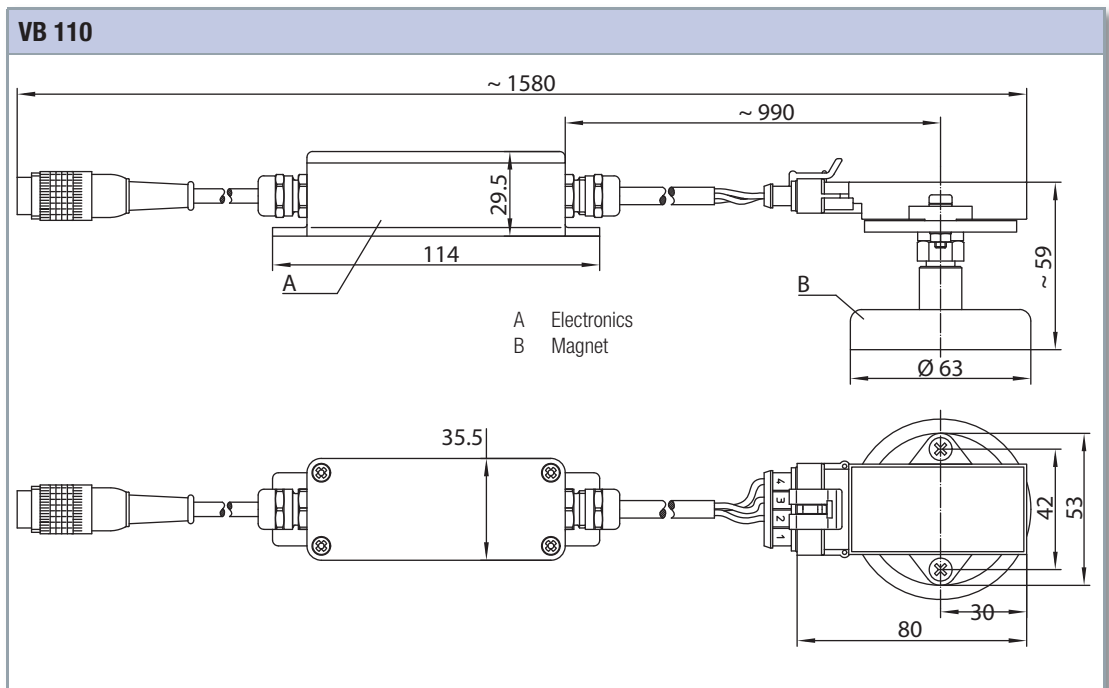

Measuring range	Weight	Order number
g	g	
± 50	547	3183-71-01.00

Counter connector



Pic.	Version	Material	Weight	For sensor	Order number
			g		
1	4 pole, M12 x 1	plastic	20	PR 130	8808-05-06.01
2	5 pole, M12 x 1	metal	60	PR 126/130 PS 120/129	8808-05-07.01
3	8 pole	plastic	30	TP 180	8808-05-09.04
4	5 pole	plastic	30	PR 310	8808-05-09.01

Connection cable



Pic.	Version	Length	Weight	For sensor	Order number
		m	g		
1	5 pole cable box, M12x1 straight, open cable ends	2.0	150	PR 126/130 PS 120/129	8824-L0-02.00
		5.0	200		8824-L0-05.00
		10.0	350		8824-L0-10.00
2	5 pole cable box, M12 x 1 / 90°, open cable ends	2.0	150	QG 107 QT 106/ 206	8824-L1-02.00
		5.0	200		8824-L1-05.00
		10.0	350		8824-L1-10.00

Connection cable



Version	Length	Weight	For sensor	Order number
	m	g		
Measuring cable MK15, 5 pole box, open cable ends	2.5	160	PR 310	8824-C1-02.50Y
	5.0	200	QG 100/110/300 QT 100/110/300	8824-C1-05.00Y
	10.0	360	QL 100/110/200 TE 110 RS 110/210	8824-C1-10.00Z

Connection cable

Version	For sensor	Order number
for connection to Hydrotechnik measuring instruments	PO 180	8824-G1-05.00Z

Inductive sensor



Version	Weight	For sensor	Order number
	g		
Frequency output	50	QT 100*/200* QL 100**	3107-00-09.00
	50	QL 200***	3107-00-09.70

* only for 31V7-... and 33V7-... / ** only for 31VB-71-35.030 / *** only for 31VB-72-35.030A2

Inductive sensor CANopen



Version	Weight	For sensor	Order number
	g		
CANopen	150	QT 106/206	3107-00-42.00

GMR sensor



Version	Weight	For sensor	Order number
	g		
Frequency output	60	QG 100/110	3107-00-45.00

High-temperature sensor



Version	Weight	For sensor	Order number
	g		
Frequency output	100	QG 107	3107-00-37.00

f/I-converter IP 40



Version	Weight	For sensor	Order number
	g		
Output signal 4 ... 20 mA, adjusted for measuring turbine	130	QT 110 (only for 31G7-...) QT 210 (only for 33G7-...) QL 110 (only for 31GB-71-35.030)	3107-00-26.00

Please send in the calibration certificate of the volume flow sensor when ordering replacement parts!

f/I-converter IP 69



Version	Weight	For sensor	Order number
	g		
Output signal 4 ... 20 mA, adjusted for measuring turbine	160	QT 118/218	3107-00-41.00

Please send in the calibration certificate of the volume flow sensor when ordering replacement parts!

f/I-converter



Version	Weight	For sensor	Order number
	g		
Output signal 4 ... 20 mA, adjusted for measuring turbine	160	QG 110 (only for 3185-... and 3885-...)	3107-00-28.00

Please send in the calibration certificate of the volume flow sensor when ordering replacement parts!

Direct connectors



Pic.	Version	P _{max}	Weight	For sensor	Order number
		bar	g		
1	straight – 1620	630	80	PR 126/130/140/ 150/155/190	2103-07-18.62N
2	90 ° – 1620		140		2146-13-05.00N
1	straight – 1620		90	PR 310	2103-07-41.62N
3	90 ° – 1620		130		2146-54-19.40N

MINIMESS® p/T-test point 1620



Version	P _{max}	Weight	For sensor	Order number
	bar	g		
Screw-in thread ISO 228 – G 1/4, form F and FKM-sealing	630	80	TE 110*	2149-04-15.53N
Screw-in thread M10x1, form G and FKM-sealing			TE 118 TP 180	2149-04-19.53N

*: not for order number 3354-10-02.00

Reflection tags



Version	Weight	For sensor	Order number
	g		
50 pc. per package	80	RS 110	8840-02-01.01

Magnetic holder



Version	Weight	For sensor	Order number
	g		
Magnetic foot with holders and fastener	380	RS 110	3130-03-01.00

Transportation case

Version	For sensor	Order number
... for load valve QL 100/110	31VB-71-35.030 31GB-71-35.030	3160-00-62.07

Notes



Please see our „MINIMESS®“ and „Measuring Systems“ catalogues. You may download them from www.hydrotechnik.com or get them from your local Hydrotechnik distributor.

HYDROTECHNIK GmbH

Holzheimer Straße 94–96 | D-65549 Limburg | Germany

Phone +49 (0) 64 31 40 04-0 | Fax +49 (0) 64 31 4 53 08

www.hydrotechnik.com | info@hydrotechnik.com

HYDROTECHNIK